

X-Treme Shank HSK X-Treme Chuck (INCH Series) NIKKEN

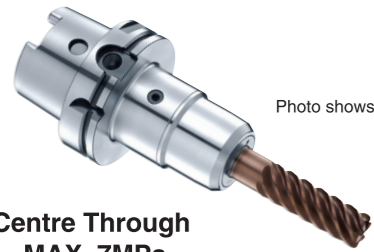
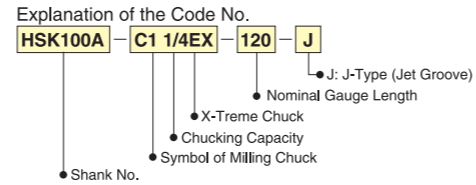
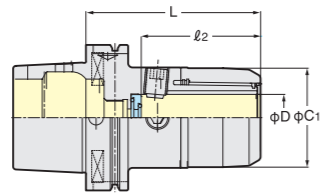

Photo shows HSK Shank.



Centre Through
MAX. 7MPa

* Inch series is for USA and semi-standard items.

PAT.P

TAPER	Code No. (D - L)	C ₁	L	L ₂	End mill with oil hole		Handle	Weight (kg)
					Stopper*	Face cap*		
HSK100A	HSK100A-C 1/2EX- 96	40	96	58	9MC 1/2HEX- 6L	9C 1/2SL-FS-EX-A1	GH16	2.7
	-C 5/8EX-106	48	106	68	9MC 5/8HEX-6.5L	9C 16SL-FS-EX-A1	GH20	3.0
	-C 3/4EX-116	55	116	71	9MC 3/4HEX- 7L	9C 3/4-FS-EX-A1	GH25	3.6
	-C1 EX-116	55	116.3	77.3	9MC 25HEX-6.2L	9C 1SL-FS-EX-A1	GH25	3.5
	-C1 1/4EX-121	68	121.3	83.3	9MC1 1/4HEX- 7L	9C1 1/4SL-FS-EX-A1	GH32	4.0
	-C1 1/2EX-136	86	136	86	9MC1 1/2HEX- 9L	9C1 1/2SL-FS-EX-A1	9HC42	5.7
NCAT50	NCAT50-C 1/2EX- 96U	40	96	58	9MC 1/2HEX- 6L	9C 1/2SL-FS-EX-A1	GH16	3.4
	-C 5/8EX-106U	48	106	68	9MC 5/8HEX-6.5L	9C 16SL-FS-EX-A1	GH20	3.8
	-C 3/4EX-106U	55	106	71	9MC 3/4HEX- 7L	9C 3/4-FS-EX-A1	GH25	4.3
	-C1 EX-111U	55	111.3	77.3	9MC 25HEX-6.2L	9C 1SL-FS-EX-A1	GH25	4.2
	-C1 1/4EX-116U	68	116.3	83.3	9MC1 1/4HEX- 7L	9C1 1/4SL-FS-EX-A1	GH32	4.7
	-C1 1/2EX-126U	86	126	86	9MC1 1/2HEX- 9L	9C1 1/2SL-FS-EX-A1	9HC42	6.2

Please use direct chucking without KM collet.

* MAX. 7MPa of center through coolant is available with the stopper.

* Please use J-type X-Treme chuck, when end mill without oil hole is used. eg) HSK100A-C1 1/4EX-121-J

In case of J-type X-Treme chuck, J-type stopper and J-type face cap (with Jet grooves) are attached. 9MC1 1/4HEX-7L-J, 9C1 1/4L-FS-EX-J
 J-type X-Treme chuck is used for the pocket milling and side milling.

Selection of the Accessories

Please select the proper stopper and the face cap according to your application. (end mill with/without coolant hole)
 The stopper and the face cap for the end mill with oil hole are attached as standard accessory.

	End mill with oil hole		End mill without oil hole		Support bolt	Drive bolt
	Stopper	Face cap	Stopper*1	Face cap (V grooves)*1		
C12EX	9MC12HEX- 6L(8.5L)*3	9C12SL-FS-EX-A1	9MC12HEX- 6L(8.5L)*3-J	9C12SL-FS-EX-J1	—	M10×16L-EX
C16EX	9MC16HEX-6.5L(9.5L)*3	9C16SL-FS-EX-A1	9MC16HEX-6.5L(9.5L)*3-J	9C16SL-FS-EX-J1	—	M12×16L-EX
C20EX*2	9MC20HEX-12L(13.5L)*3	9C20 -FS-EX-A1	9MC20HEX-12L(13.5L)*3-J	9C20 -FS-EX-J1	FSMB12-20	M12×20L-EX
C25EX	9MC25HEX-6.2L(8.7L)*3	9C25SL-FS-EX-A1	9MC25HEX-6.2L(8.7L)*3-J	9C25SL-FS-EX-J1	FSMB16-20-H8	M16×20L-EX
C32EX	9MC32HEX-7L(10L)*3	9C32SL-FS-EX-A1	9MC32HEX-7L(10L)*3-J	9C32SL-FS-EX-J1		
C42EX	9MC42HEX-9L(11.5L)*3	9C42SL-FS-EX-A1	9MC42HEX-9L(11.5L)*3-J	9C42SL-FS-EX-J1		



O-ring
Please insert the stopper which small hole diameter is located at the end mill side. (C42: Same hole diameter)



Cross groove
Please insert the stopper which cross groove is located at the end mill side.



*1 Please contact us for the stopper for X-Treme chuck Inch series.

*2 The Code No. of the stopper for NBT40-C20EX, HSK63A-C20EX and C8-C20EX is 9MC20HEX-7L(8.5L)

*3 The length in () is used for Code No. of extended stopper. eg. 9MC32HEX-10L

It can be used, when length of end mill become shorter after re-grinding.

* X-Treme chuck with nose ring for C spanner is available as an option.

Please add "-A" at the end of Code No.

eg) NBT50-C25EX-116-J-A

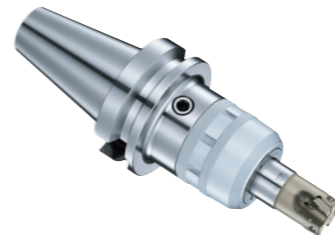

Nose ring with C spanner

Chuck	Handle
12EX-○○○-A	9HC16
16EX-○○○-A	9HC22
20EX-○○○-A	9HC25
25EX-○○○-A	9HC25
32EX-○○○-A	9HC32
42EX-○○○	9HC42

NIKKEN KOSAKUSHO WORKS, LTD. OSAKA, JAPAN.

5-1, 1-chome, Minamishinden, Daito-shi, Osaka-fu, Japan, Telephone : +81 (0) 72-869-5820 Telefax : +81 (0) 72-869-6220

U.S.A	LYNDEX-NIKKEN Tel.+1-847-367-4800	ITALY	VEGA INTERNATIONAL TOOLS S.P.A Tel.+39-011-9497911	TURKEY	NIKKEN KESQ TAKIMLAR SAN. VE UUSLARARAS TIC. AS Tel.+90-(0)-216-518-1010
MEXICO	HERRAMIENTAS LYNDEX-NIKKEN S.A. DE CV. Tel.+52-55-8421-8421	SWITZERLAND	NIKKEN SWITZERLAND AG Tel.+41-(0)-41-748-5000	KOREA	KOREA NIKKEN LTD. Tel.+82-(0)-32-763-4461
FRANCE	PROCOMO-NIKKEN S.A.S Tel.+33-(0)-1-69.19.17.35	SCANDINAVIA SWEDEN	NIKKEN SCANDINAVIA AB Tel.+46-(0)-303-440-600	P.R.CHINA	SHANGHAI ZHONG YAN TRADING CO., LTD Tel.+86-(0)-216210-2506
UK	NIKKEN KOSAKUSHO UK LTD. Tel.+44-(0)-1709-366306	SPAIN	CUTTING TOOL S.L (TOOLING) Tel.+34-(0)-902-820090	SINGAPORE	NIKKEN KOSAKUSHO ASIA PTE, LTD Tel.+65-6362-7980
F.R.GERMANY	NIKKEN DEUTSCHLAND GmbH Tel.+49-(0)-6142-550600	PORTUGAL	NIKKEN EUROPE DIMSORES ESPANA (CNC ROTARY TABLE) Tel.+34-(0)-669-603433	THAILAND	SIAM NIKKEN Co., LTD. Tel.+66(02)178-0503

http://www.nikken-kosakusho.co.jp
e-mail:osaka@nikken-kosakusho.co.jp

Please give your order to the following agent.

D.JJ.0.5

NEW

NIKKEN

X-Treme Shank & X-Treme Chuck

Excellent Run-out & Powerful Gripping

JAPAN,EU PAT.
USA.CHINA. PAT.P

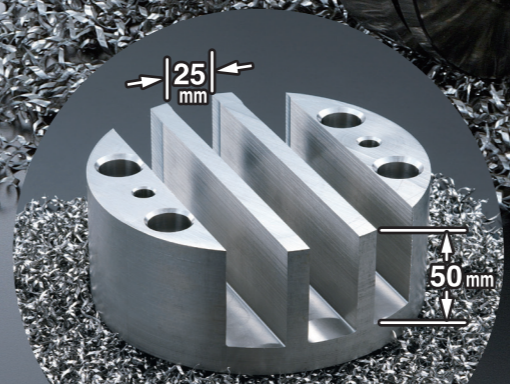

Material: Ti6Al4V Titanium
25mm, 6teeth
Carbide Roughing End Mill
25 X Depth 50mm 1 Path Milling
Never Pull-Out

Industry proven to eliminate Pull-Out.

Exclusively developed for demanding Applications and materials associated With the aircraft and energy industry.

NIKKEN KOSAKUSHO WORKS, LTD.
CAT.NO.2881

X-Treme Shank 2LOCK NBT X-Treme Chuck

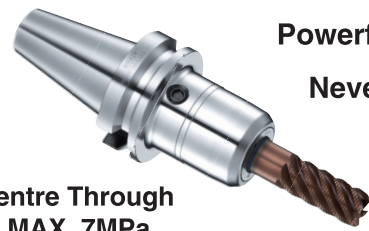

Powerful Gripping & Never Pull-out

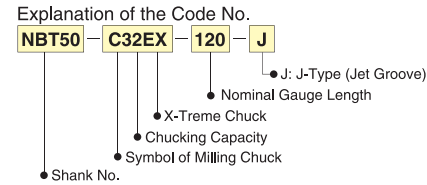
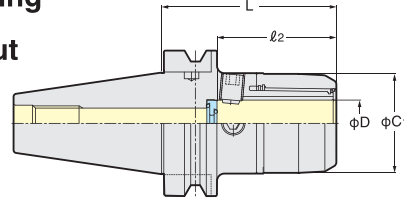

Centre Through
MAX. 7MPa

PAT.P

TAPER	Code No. (φD - L)	C ₁	L	ℓ ₂	End mill with oil hole		Handle	Weight (kg)
					Stopper*	Face cap*		
No.40	NBT40-C12EX- 86	40	86	58	9MC12HEX- 6L	9C12SL-FS-EX-A1	GH16	1.6
	-C16EX- 96	48	96	68	9MC16HEX-6.5L	9C16SL-FS-EX-A1	GH20	1.7
	-C20EX- 96	55	96	71	9MC20HEX- 7L	9C20 -FS-EX-A1	GH25	1.8
No.50	NBT50-C12EX- 96	40	96	58	9MC12HEX- 6L	9C12SL-FS-EX-A1	GH16	4.0
	-C16EX-106	48	106	68	9MC16HEX-6.5L	9C16SL-FS-EX-A1	GH20	4.4
	-C20EX-116	55	116	71	9MC20HEX- 12L	9C20 -FS-EX-A1	GH25	5.0
	-C25EX-116	55	116.3	77.3	9MC25HEX-6.2L	9C25SL-FS-EX-A1	GH25	4.8
	-C32EX-121	68	121.3	83.3	9MC32HEX- 7L	9C32SL-FS-EX-A1	GH32	5.3
-C42EX-126	86	126	86	9MC42HEX- 9L	9C42SL-FS-EX-A1	9HC42	6.3	

Please use direct chucking without KM collet.

★ MAX. 7MPa of center through coolant is available with the stopper.

★ Please use J-type X-Treme chuck, when end mill without oil hole is used. eg) NBT50-C32EX-121-J

In case of J-type X-Treme chuck, J-type stopper and J-type face cap (with Jet grooves) are attached. 9MC32HEX-7L-J, 9C32L-FS-EX-J1

J-type X-Treme chuck is used for the pocket milling and side milling.

★ Extended length X-Treme chuck is also available. NBT50-C20EX-136, NBT50-C25EX-136, NBT50-C32EX-136

2LOCK tooling (NBT) can be used as the double face contact tooling on the M/C where spindle is BT double face contact system.

2LOCK tooling can also be used on the M/C with BT standard spindle.

X-Treme Shank 2LOCK NIT/NCAT X-Treme Chuck

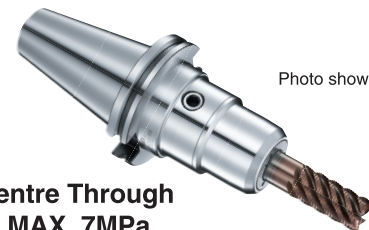
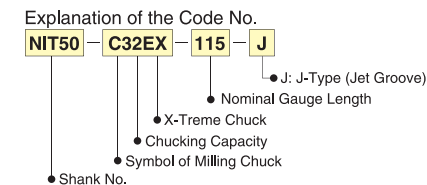
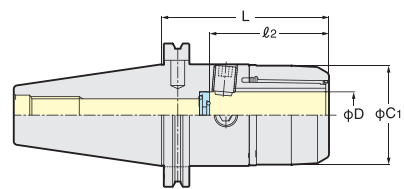

Photo shows NIT Shank.



Centre Through
MAX. 7MPa

PAT.P

TAPER	Code No. (φD - L)	C ₁	L	ℓ ₂	End mill with oil hole		Handle	Weight (kg)
					Stopper*	Face cap*		
NIT50	NIT50 -C12EX- 96	40	96	58	9MC12HEX- 6L	9C12SL-FS-EX-A1	GH16	3.4
	-C16EX-106	48	106	68	9MC16HEX-6.5L	9C16SL-FS-EX-A1	GH20	3.8
	-C20EX-106	55	106	71	9MC20HEX- 12L	9C20 -FS-EX-A1	GH25	4.3
	-C25EX-111	55	111.3	77.3	9MC25HEX-6.2L	9C25SL-FS-EX-A1	GH25	4.2
	-C32EX-116	68	116.3	83.3	9MC32HEX- 7L	9C32SL-FS-EX-A1	GH32	4.7
-C42EX-126	86	136	86	9MC42HEX- 9L	9C42SL-FS-EX-A1	9HC42	6.0	
NCAT50	NCAT50-C12EX- 96U	40	96	58	9MC12HEX- 6L	9C12SL-FS-EX-A1	GH16	3.4
	-C16EX-106U	48	106	68	9MC16HEX-6.5L	9C16SL-FS-EX-A1	GH20	3.8
	-C20EX-106U	55	106	71	9MC20HEX- 12L	9C20 -FS-EX-A1	GH25	4.3
	-C25EX-111U	55	111.3	77.3	9MC25HEX-6.2L	9C25SL-FS-EX-A1	GH25	4.2
	-C32EX-116U	68	116.3	83.3	9MC32HEX- 7L	9C32SL-FS-EX-A1	GH32	4.7
-C42EX-126U	86	126	86	9MC42HEX- 9L	9C42SL-FS-EX-A1	9HC42	6.0	

Please use direct chucking without KM collet.

★ 2LOCK tooling (NIT/NCAT) can be used as the double face contact tooling on the M/C where spindle is BT double face contact system.

2LOCK tooling can also be used on the M/C with IT/CAT standard spindle.

★ MAX. 7MPa of center through coolant is available with the stopper.

★ Please use J-type X-Treme chuck, when end mill without oil hole is used. eg) NCAT50-C32EX-116U-J

In case of J-type X-Treme chuck, J-type stopper and J-type face cap (with Jet grooves) are attached. 9MC32HEX-7L-J, 9C32L-FS-EX-J1

J-type X-Treme chuck is used for the pocket milling and side milling.

X-Treme Shank HSK X-Treme Chuck

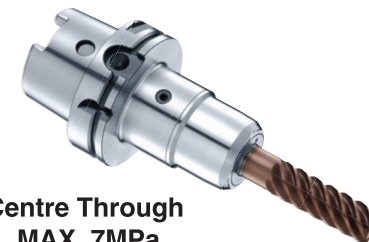

Centre Through
MAX. 7MPa

PAT.P

TAPER	Code No. (φD - L)	C ₁	L	ℓ ₂	End mill with oil hole		Handle	Weight (kg)
					Stopper*	Face cap*		
HSK63A	HSK 63A-C12EX- 96	40	96	58	9MC12HEX- 6L	9C12SL-FS-EX-A1	GH16	1.3
	-C16EX-101	48	101	68	9MC16HEX-6.5L	9C16SL-FS-EX-A1	GH20	1.5
	-C20EX-106	55	106	71	9MC20HEX- 7L	9C20 -FS-EX-A1	GH25	1.7
HSK100A	HSK100A-C12EX- 96	40	96	58	9MC12HEX- 6L	9C12SL-FS-EX-A1	GH16	2.7
	-C16EX-106	48	106	68	9MC16HEX-6.5L	9C16SL-FS-EX-A1	GH20	3.0
	-C20EX-116	55	116	71	9MC20HEX- 12L	9C20 -FS-EX-A1	GH25	3.6
	-C25EX-116	55	116.3	76.3	9MC25HEX-6.2L	9C25SL-FS-EX-A1	GH25	3.5
	-C32EX-121	68	121.3	83.3	9MC32HEX- 7L	9C32SL-FS-EX-A1	GH32	4.0
-C42EX-136	86	136	86	9MC42HEX- 9L	9C42SL-FS-EX-A1	9HC42	5.7	
HSK125A	HSK125A-C20EX-121S	55	121	71	9MC20HEX- 12L	9C20 -FS-EX-A1	GH25	5.4
	-C25EX-121S	55	121.3	77.3	9MC25HEX-6.2L	9C25SL-FS-EX-A1	GH25	5.3
	-C32EX-136S	68	136.3	83.3	9MC32HEX- 7L	9C32SL-FS-EX-A1	GH32	6.3
	-C42EX-136S	86	136	86	9MC42HEX- 9L	9C42SL-FS-EX-A1	9HC42	7.1

Please use direct chucking without KM collet.

★ MAX. 7MPa of center through coolant is available with the stopper.

★ Please use J-type X-Treme chuck, when end mill without oil hole is used. eg) HSK125A-C32EX-136S-J

In case of J-type X-Treme chuck, J-type stopper and J-type face cap (with Jet grooves) are attached. 9MC32HEX-7L-J, 9C32L-FS-EX-J1

J-type X-Treme chuck is used for the pocket milling and side milling.

X-Treme Shank C8 X-Treme Chuck

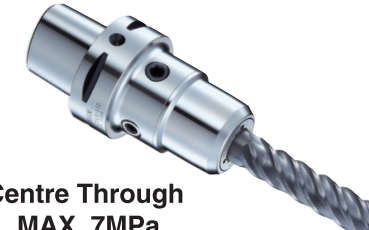

Centre Through
MAX. 7MPa

PAT.P

TAPER	Code No. (φD - L)	C ₁	L	ℓ ₂	End mill with oil hole		Handle	Weight (kg)
					Stopper*	Face cap*		
C8	C8-C20EX-106	55	106	71	9MC20HEX- 7L	9C20 -FS-EX-A1	GH25	3.0
	-C25EX-111	55	111.3	77.3	9MC25HEX-6.2L	9C25SL-FS-EX-A1	GH25	3.0
	-C32EX-116	68	116.3	83.3	9MC32HEX- 7L	9C32SL-FS-EX-A1	GH32	3.5

Please use direct chucking without KM collet.

★ MAX. 7MPa of center through coolant is available with the stopper.

★ Please use J-type X-Treme chuck, when end mill without oil hole is used. eg) C8-C32EX-116-J

In case of J-type X-Treme chuck, J-type stopper and J-type face cap (with Jet grooves) are attached. 9MC32HEX-7L-J, 9C32L-FS-EX-J1

J-type X-Treme chuck is used for the pocket milling and side milling.

How to exchange the face caps

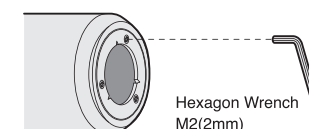

The face cap is fixed with 3 pieces of M2.5 screws. (C42EX: M3) The face cap must be centred or centralized, when exchanged. The special centering jig fixture and wrench are provided as an option.

	Screw
C12EX, C16EX, C20EX	M2.5-6L
C25EX, C32EX	SNSS-M2.5 × 6-SD
C42EX	CBS3-6

Please refer P.3 the accessories such as the stopper and face cap.