

NIKKEN

CNC ROTARY TABLE

for BROTHER COMPACT MACHINING CENTRE

SPEEDIO



BT30 TOOLING



CNC205L SA-BR2



5AX-100 SA-BR2

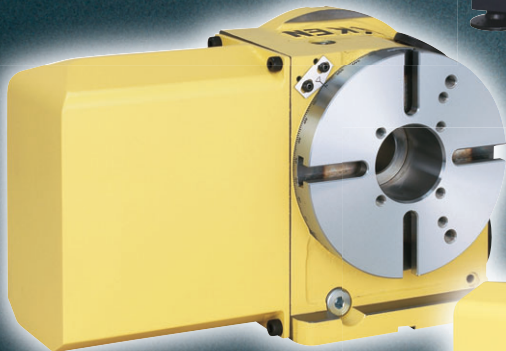

CNC180L SA-BR2

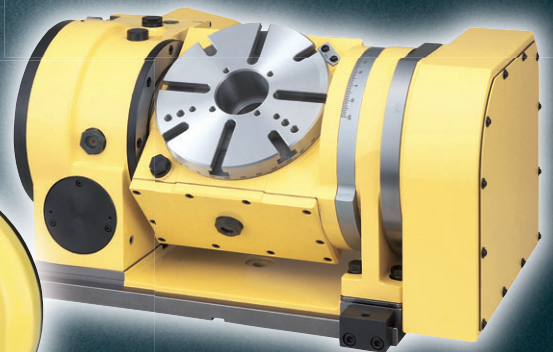

5AX-201 SA-BR2

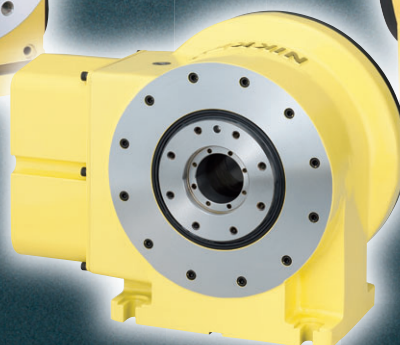

DD250LS-50

NIKKEN KOSAKUSHOWORKS, LTD.
CAT.NO.8306E

ANTI-WEARING, HIGH RIGIDITY and HIGH SPEED ROTATION

Worldwide Field-proven NIKKEN CNC Rotary Table



Worm Wheel

Material is special NIKKEN order made steel. Specially hardened and furthermore ion-nitrided on the tooth. Thus, the problem of the sliding friction is solved. The hardness of the tooth surface and inside is shown at right hand side.

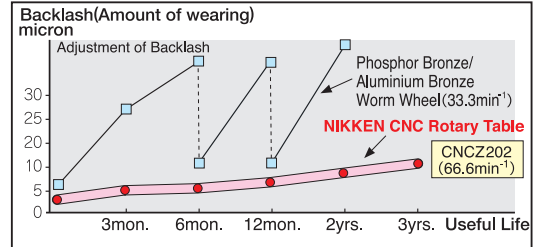
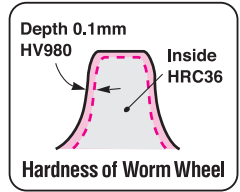

It is not exaggeration that the most important parts of the CNC rotary table is worm system. Please choose NIKKEN CNC rotary table with special worm system for our anti-wearing, high rigidity and high speed rotation.

Work Sample

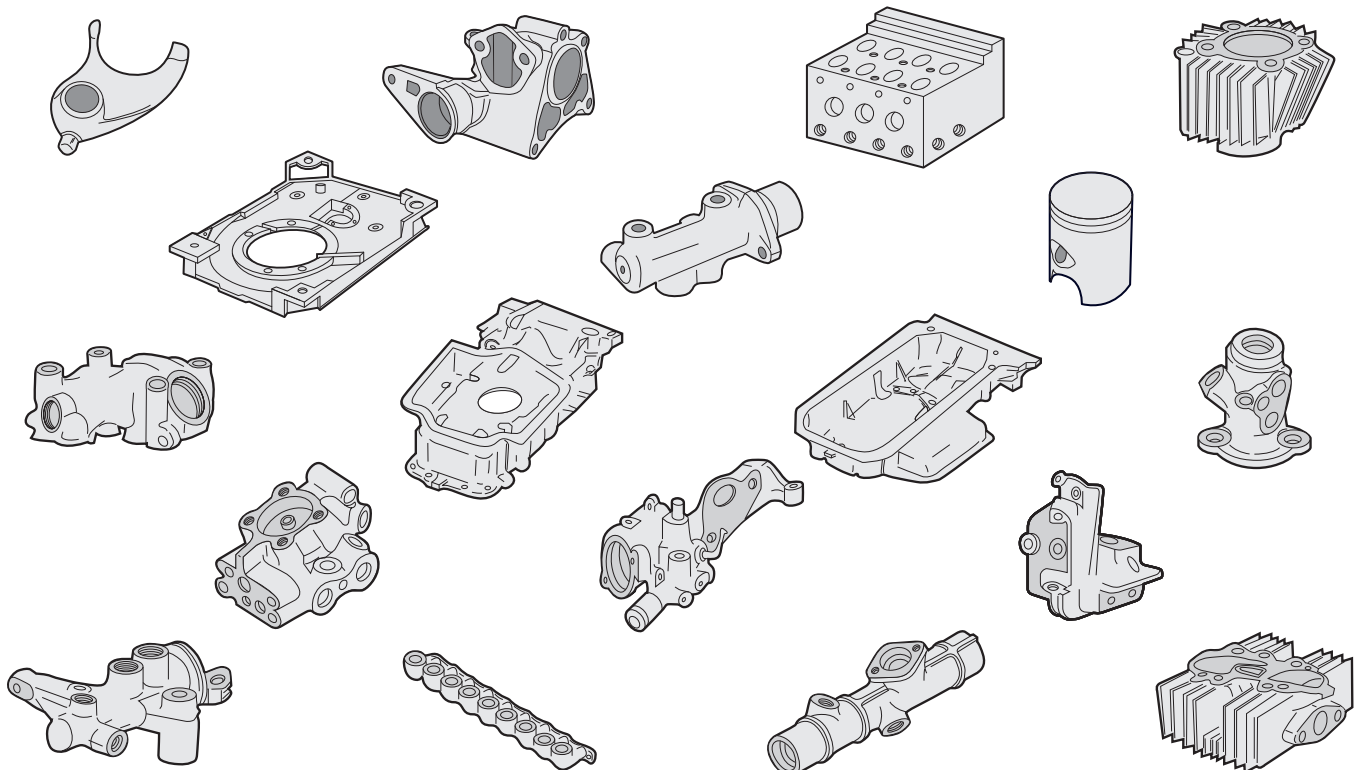

CNC ROTARY TABLE for *SPEEDIO*



The servo motor and the amplifier of the rotary table for *SPEEDIO* are special one only for *SPEEDIO*.

The existing servo motors or the amplifiers for BROTHER TAPPING CENTER can not be used.

Please specify the machine name and the layout of the rotary table, when ordering. Standard layout of the rotary table is to install the left-handed rotary table on the left side of the machine.

The amplifier, all cables and the rotary table with the suitable servo motor will be supplied from NIKKEN. Installation fee will be charged separately.

SPEEDIO S300X1 ☞ P.3	CNC105LSA-BR2
	CNC180LSA-BR2, 202LSA-BR2
	CNC205LSA-BR2 (Trunnion)
	5AX-100SA-BR2 DD250LS-50
SPEEDIO (S500X1) (S700X1) ☞ P.5 S1000X1 ☞ P.9	CNC180LSA-BR2, 202LSA-BR2
	CNC205LSA-BR2 (Trunnion)
	CNC260LSA-BR2, 302LSA-BR2
	5AX-130SA-BR2
	5AX-201SA-BR2
	DD250LS-50

SPEEDIO R450X1 *1 (With Pallet Changer) ☞ P.13	CNC105LSA-BR2
	CNC180LSA-BR2, 202LSA-BR2
	CNC205LSA-BR2 (Trunnion)
	5AX-130BASA-BR2
SPEEDIO R650X1 *2 (With Pallet Changer) ☞ P.15	CNC105LSA-BR2
	CNC180LSA-BR2, 202LSA-BR2
	CNC205LSA-BR2 (Trunnion)
	5AX-130BASA-BR2
	5AX-2MT-105-120SA-BR2
	DD250LS-50

Basically, 2sets are needed for pullee changer

Please specify the options

	R450X1		R650X1	
	Standard	Option	Standard	Option
Swing Dia.(mm)	1,020	1,100	1,250	1,300
JIG Height(mm)	300	350	350	420
Load (kg)	120	200	200	300

★Option can be selected independently.

CNC Rotary Table for TC-S2DN, TC-R2B, TC-32BNQT, TC-32BNFT, TC-22B

The servo motor and the amplifier are different from the one for *SPEEDIO*. Please ask us for more detail.

CNC-A00:SAIII

TAPPING CENTER	CNC ROTARY TABLE
TC-S2A	CNC180LSAIII, 202LSAIII
	5AX-130SAIII

★High speed rotation Z series is also available.

CNC-B00:SA-BR

TAPPING CENTER	CNC ROTARY TABLE
TC-S2D	CNC105LSA-BR
	CNC180LSA-BR, 202LSA-BR
	CNC260LSA-BR
	5AX-130SA-BR, 5AX-201SA-BR
TC-31B*1 (With Pallet Changer)	CNC105LSA-BR
TC-R2B*1 (With Pallet Changer)	CNC105LSA-BR
	CNC180LSA-BR, 202LSA-BR
	5AX-130BASA-BR

★High speed rotation Z series is also available.

★The machine marked *1 is equipped with the pallet changer. So, 2 set of the rotary table will be installed.

CNC-B00:YA-BR

TAPPING CENTER	CNC ROTARY TABLE
TC-22B	CNC180LYA-BR, 202LYA-BR
	CNC260LYA-BR
	5AX-130YA-BR, 5AX-201YA-BR
TC-32BNFT	CNC180LYA-BR, 202LYA-BR
	CNC260LYA-BR
	5AX-130YA-BR, 5AX-201YA-BR
	5AX-350BAYA-BR
TC-32BNQT*1 (With Pallet Changer)	CNC180LYA-BR, 202LYA-BR
	5AX-130BAYA-BR
	5AX-2MT-105-120BAYA-BR

★High speed rotation Z series is also available.

★The machine marked *1 is equipped with the pallet changer. So, 2 set of the rotary table will be installed.

★The special agreement should be taken for 5AX-350BAYA-BR, please ask us for more detail.

CNC ROTARY TABLE order check sheet for BROTHER

CNC ROTARY TABLE MODEL : _____

Qty : _____

BROTHER MODEL : _____

Table size : Standard option _____

Colum height : Standard high Colum _____

Country of Destination : _____

End User : _____

Position of CNC ROTARY TABLE MODEL : Left Right _____

Ceiling cover : Full cover, without cover _____

Cable Position of Ceiling cover : Left Right _____

Application : Table only Trunnion Jig _____

Support Table : without with(_____)

Meeting with set maker : No Yes(_____)

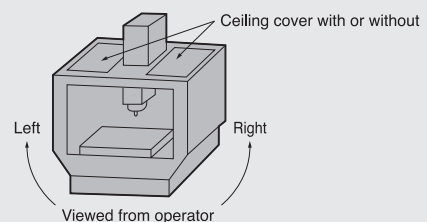

CNC ROTARY TABLE for *SPEEDIO S300X1*



CNC105LSA-BR2

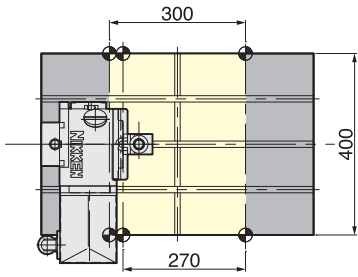

φ105mm type CNC ROTARY TABLE

- Diameter of Table :φ105mm
- MAX. Work Load :30kg
- MAX. Rotation Speed :22.2 (min⁻¹), **44.4 (min⁻¹)*1**
- Indexing Accuracy :±20sec.
- Brake Torque :205Nm
- Net Weight :30kg
- Servo Motor :R2AAB8100HXPGA
- Spindle Hole :φ60mm_{H7}×φ30mm Through Hole

*1:High speedio Z series.

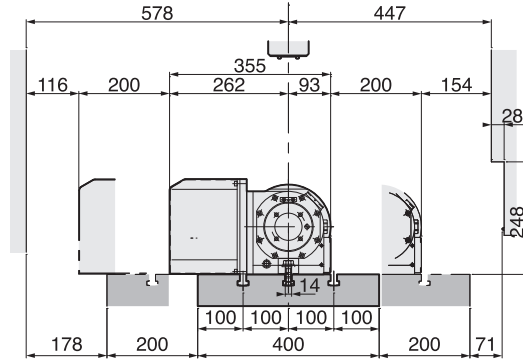
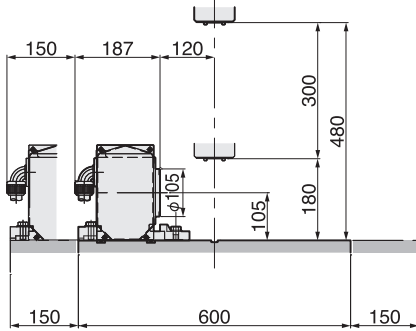

CNC180LSA-BR2

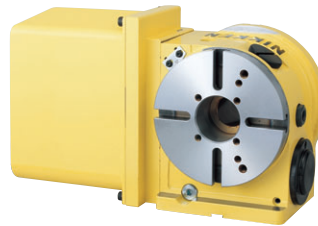
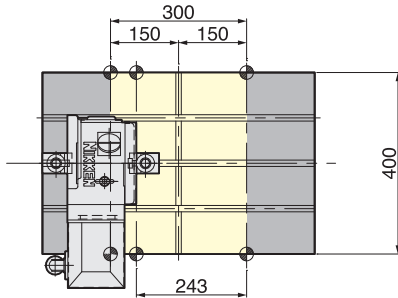

φ180mm type CNC ROTARY TABLE

- Diameter of Table :φ180mm
- MAX. Work Load :100kg (Vertical) 200kg (Horizontal)
- MAX. Rotation Speed :22.2 (min⁻¹), **44.4 (min⁻¹)*1**
- Indexing Accuracy :±20sec.
- Brake Torque :303Nm
- Net Weight :48kg
- Servo Motor :R2AAB8100HXPGA
- Spindle Hole :φ60mm_{H7}×φ40mm Through Hole

*1:High speedio Z series.

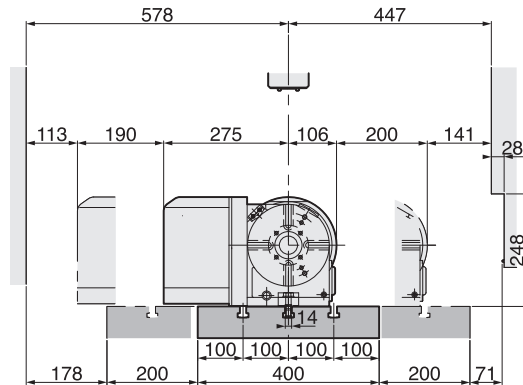
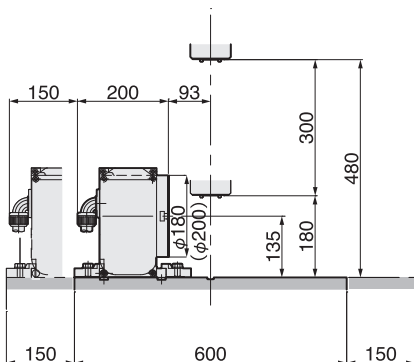

CNC105LSA-BR2

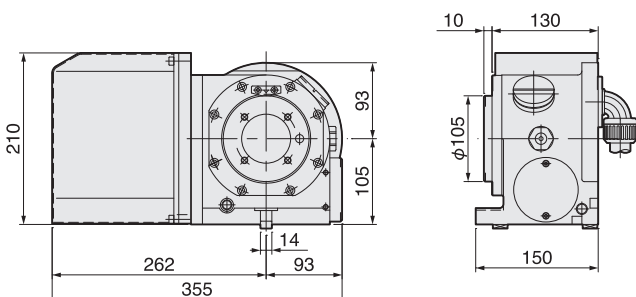

CNC180LSA-BR2 CNC202LSA-BR2 is also available

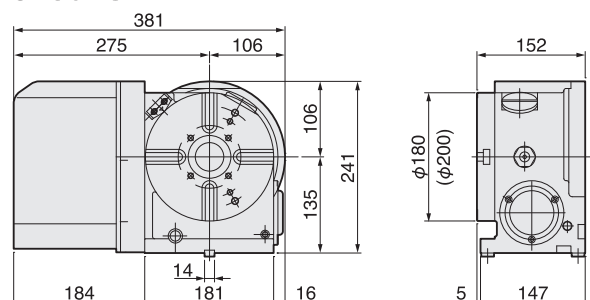

CNC ROTARY TABLE for *SPEEDIO S300X1*



CNC205LSA-BR2(CST100-135) Trunnion type Table

NEW

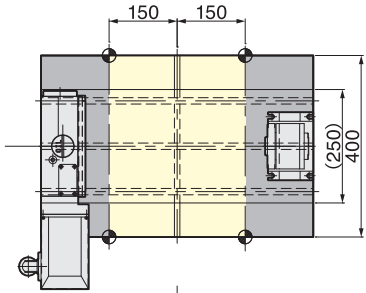

φ200mm Slim type CNC ROTARY TABLE

- Diameter of Table :φ200mm
 - MAX. Work Load :100kg (with support table)
 - MAX. Rotation Speed :22.2 (min⁻¹), 44.4 (min⁻¹)*1
 - Indexing Accuracy :±20sec.
 - Brake Torque :380Nm
 - Net Weight :45kg
 - Servo Motor :R2AAB8100HXPGA
 - 6 ports built rotary joint can be fitted
- *1:High speedio Z series.

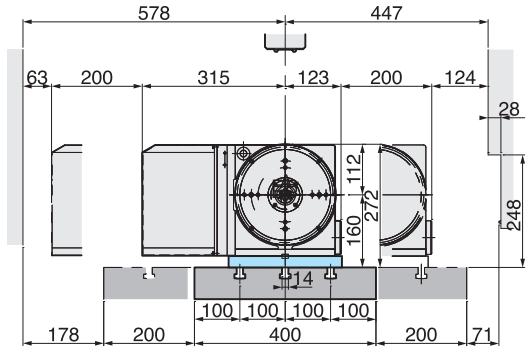
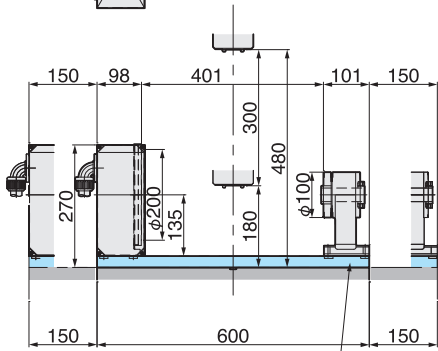

Please provide the plate by yourself.

5AX-100SA-BR2

NEW



φ100mm Compact type 5AX- TILTING ROTARY TABLE

- Diameter of Table :φ90mm
- MAX. Work Load :20kg (Vertical) 40kg (Horizontal)
- MAX. Rotation Speed :44.4 (min⁻¹) (Rotary), 22.2 (min⁻¹) (Tilting)
- Indexing Accuracy :±30sec. (Rotary), 60sec. (Tilting)
- Brake Torque :200Nm (Rotary), 410Nm (Tilting)
- Servo Motor :R2AD08040FXPG3 (Rotary)
R2AD08040FXPG3 (Tilting)
- Spindle Hole :φ50mm_{H7}×φ30mm Through Hole
- Tilting Angle :0°~105°

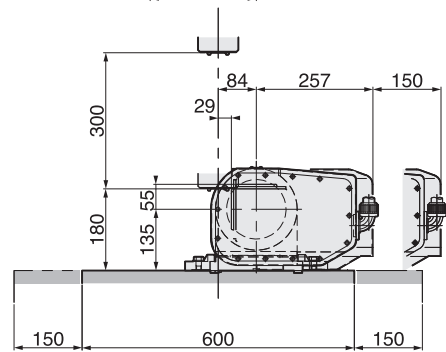
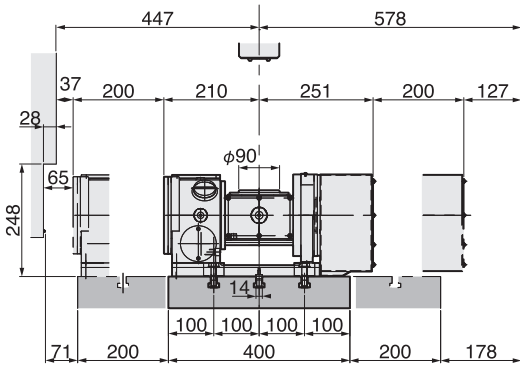
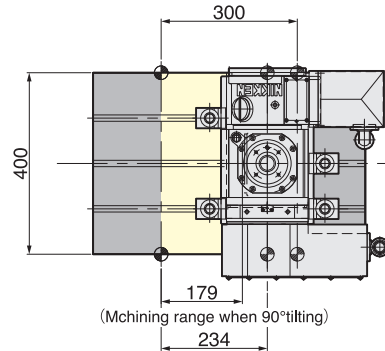

CNC205LSA-BR2

CST100-135

5AX-100SA-BR2

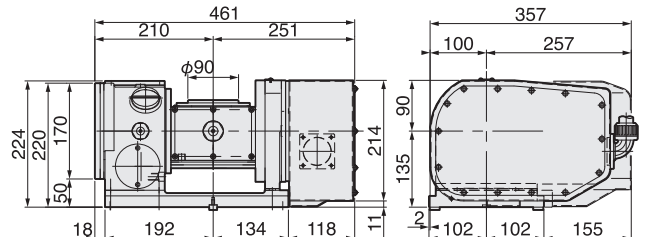
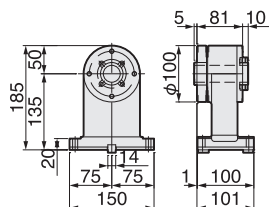
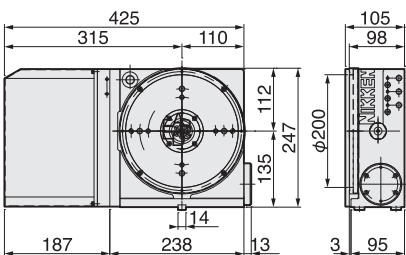

CNC ROTARY TABLE for SPEEDIO S500X1/S700X1



CNC180LSA-BR2

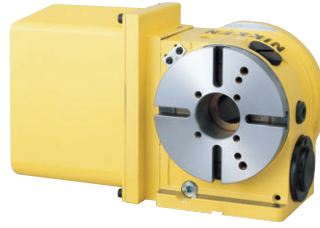
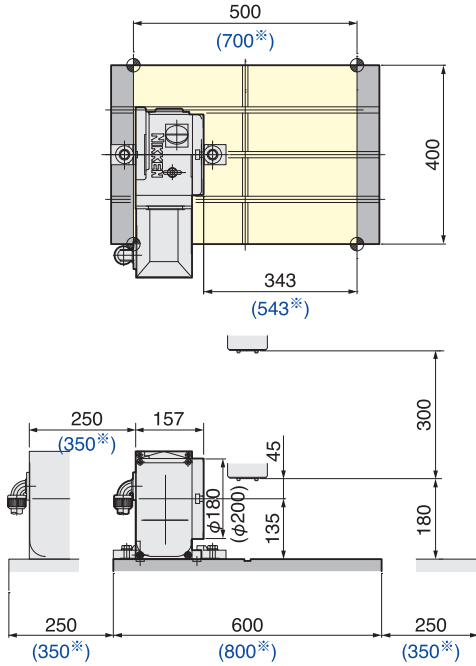

180mm type CNC ROTARY TABLE

- Diameter of Table : 180mm
 - MAX. Work Load :100kg (Vertical) 200kg (Horizontal)
 - MAX. Rotation Speed :22.2 (min⁻¹), **44.4 (min⁻¹)*1**
 - Indexing Accuracy :±20sec.
 - Brake Torque :303Nm
 - Net Weight :48kg
 - Servo Motor :R2AAB8100HXPGA
 - Spindle Hole : 60mm \varnothing ×40mm Through Hole
- *1:High speedio Z series.

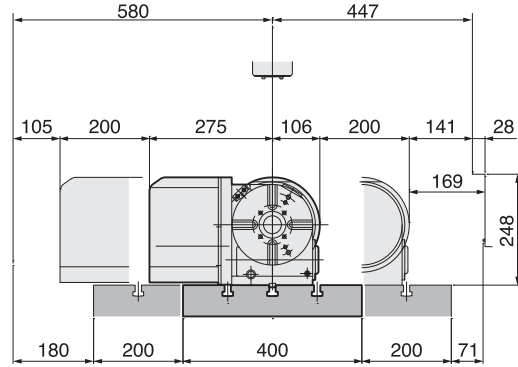

(*)The figures with blue color are the figures for S700X1.

CNC260LSA-BR2

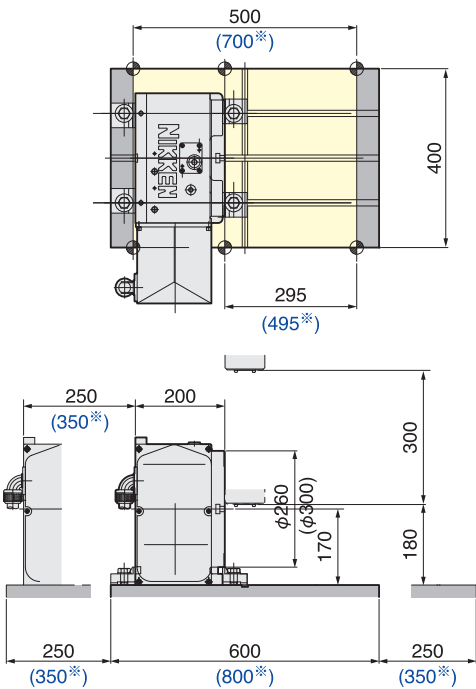

260mm type CNC ROTARY TABLE

- Diameter of Table : 260mm
 - MAX. Work Load :300kg (Vertical) 150kg (Horizontal)
 - MAX. Rotation Speed :16.6 (min⁻¹), **33.3 (min⁻¹)*1**
 - Indexing Accuracy :±20sec.
 - Brake Torque :588Nm (Pneumatic), 1568Nm (Hydraulic)
 - Net Weight :120kg
 - Servo Motor :R2AAB8100HXPGA
 - Spindle Hole : 80mm \varnothing Through Hole
- *1:High speedio Z series.

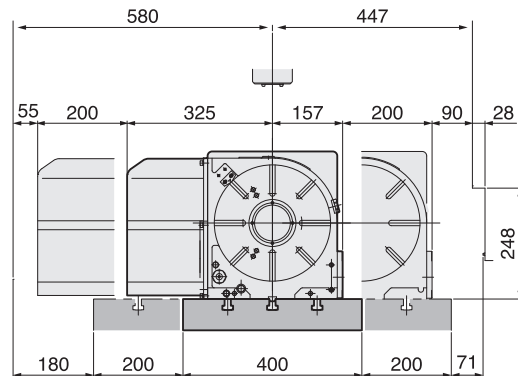

(*)The figures with blue color are the figures for S700X1.

CNC180LSA-BR2 CNC202LSA-BR2 is also available.

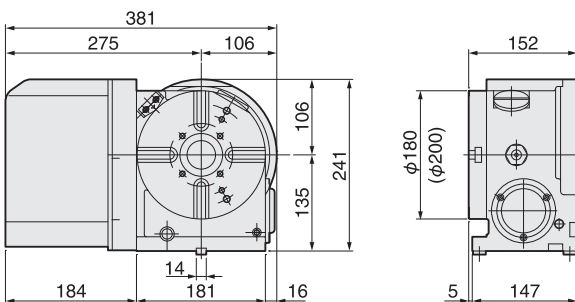

CNC260LSA-BR2 CNC302LSA-BR2 is also available.

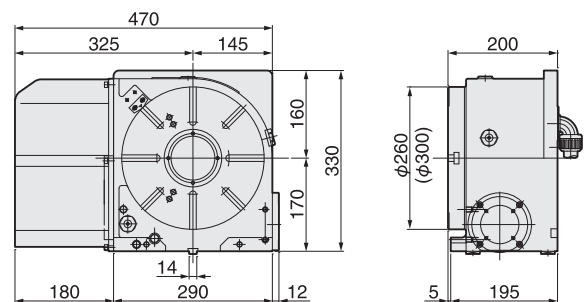

CNC ROTARY TABLE for SPEEDIO S500X1/S700X1



5AX-130SA-BR2

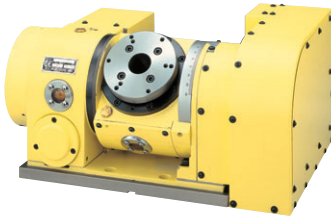

130mm type 5AX- TILTING ROTARY TABLE

- Diameter of Table : 130mm (With 130mm sub table)
- MAX. Work Load :25kg (Vertical) 50kg (Horizontal)
- MAX. Rotation Speed :22.2 (min⁻¹) (Rotary), 11.1 (min⁻¹) (Tilting)
- Indexing Accuracy :±30sec. (Rotary), 60sec. (Tilting)
- Brake Torque :205Nm (Rotary), 303Nm (Tilting)
- Net Weight :115kg
- Servo Motor :R2AAB8100HXPGA (Rotary)
R2AAB8100HXPGA (Tilting)
- Spindle Hole : 60mm_{H7}×30mm Through Hole
- Tilting Angle :0°~105°

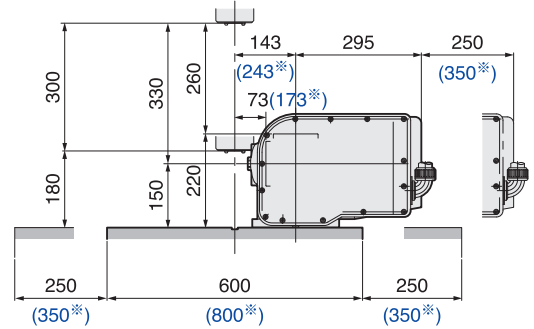
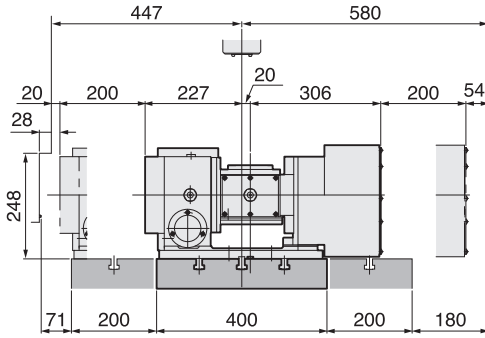
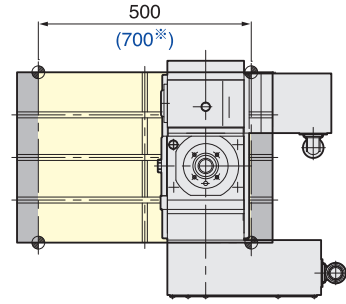

(*)The figures with blue color are the figures for S700X1.

5AX-201SA-BR2

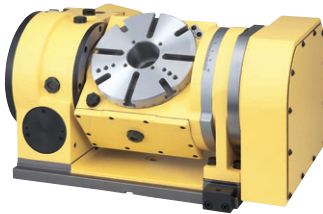

200mm type 5AX- TILTING ROTARY TABLE

- Diameter of Table : 200mm
- MAX. Work Load :40kg (Vertical) 60kg (Horizontal)
- MAX. Rotation Speed :22.2 (min⁻¹) (Rotary), 16.6 (min⁻¹) (Tilting)
- Indexing Accuracy :±20sec. (Rotary), 60sec. (Tilting)
- Brake Torque :588Nm (Rotary), 608Nm (Tilting) (Hydraulic)
303Nm (Rotary), 303Nm (Tilting) (Pneumatic)
- Net Weight :160kg
- Servo Motor :R2AAB8100HXPGA (Rotary)
R2AAB8100HXPGA (Tilting)
- Spindle Hole : 60mm_{H7}×50mm Through Hole
- Tilting Angle :0°~105°

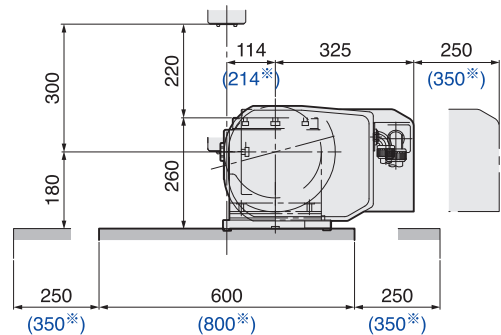
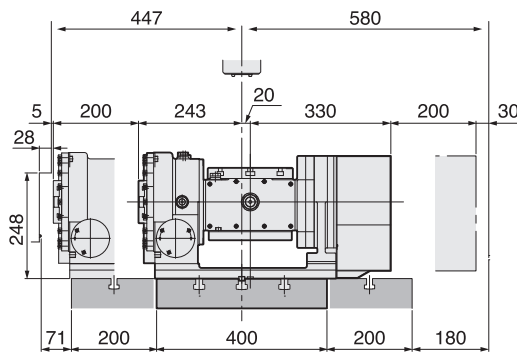
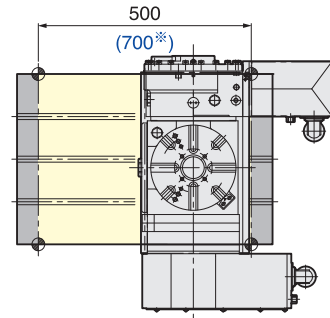

(*)The figures with blue color are the figures for S700X1.

5AX-130SA-BR2

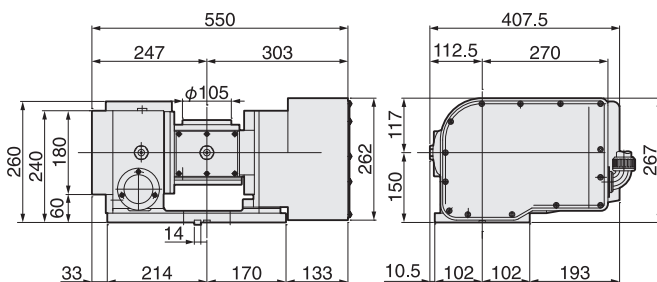

5AX-201SA-BR2

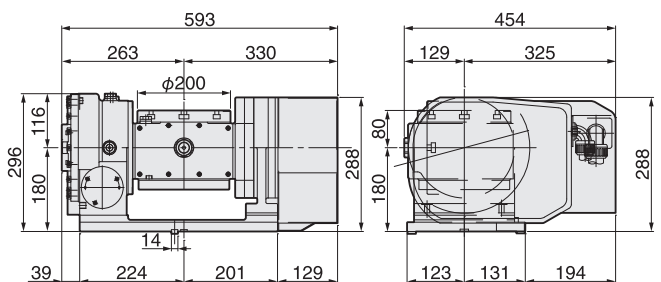

S500X1
S700X1

CNC ROTARY TABLE for SPEEDIO S500X1/S700X1

NIKKEN

NEW

CNC205LSA-BR2(TAT105N-135)

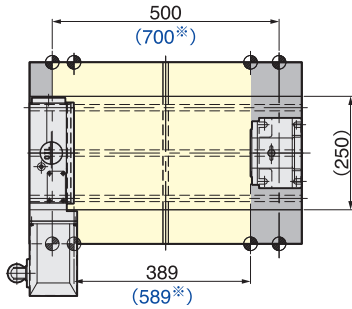

φ200mm Slim type CNC ROTARY TABLE

- Diameter of Table :φ200mm
- MAX. Work Load :100kg (with supprt table)
- MAX. Rotation Speed :22.2 (min⁻¹), **44.4 (min⁻¹)*1**
- Indexing Accuracy :±20sec.
- Brake Torque :380Nm
- Net Weight :45kg
- Servo Motor :R2AAB8100HXPGA
- 6 ports buit rotary joint can be fitted

*1:High speedio Z series.

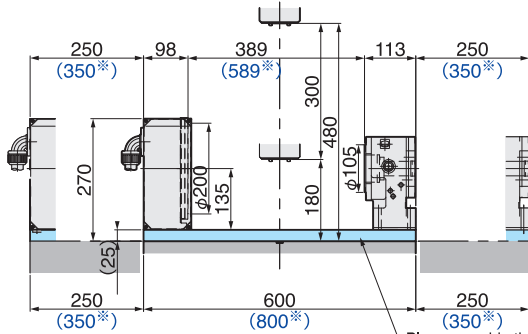

Please provide the plate by yourself.

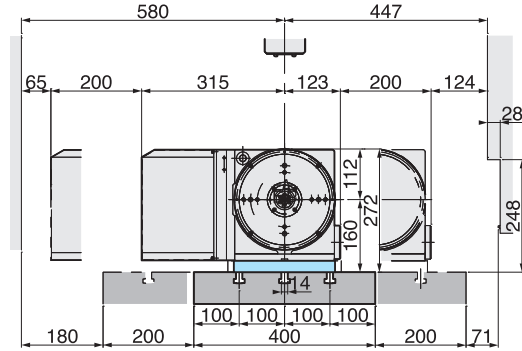

(*)The figures with blue color are the figures for S700X1.

CNC205LSA-BR2

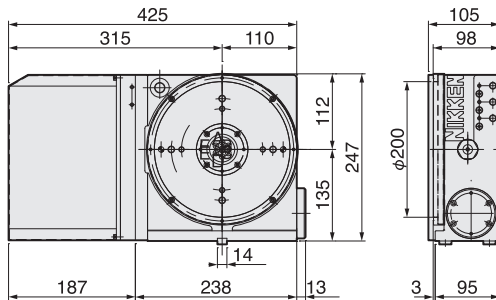

TAT105N-135

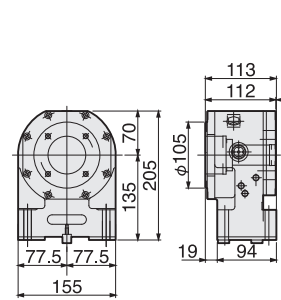

CNC ROTARY TABLE & SUPPORT TABLE with JIG FIXTURE

NIKKEN



CNC180L (with 6+1 port Rotary joint) & TAT105N-135

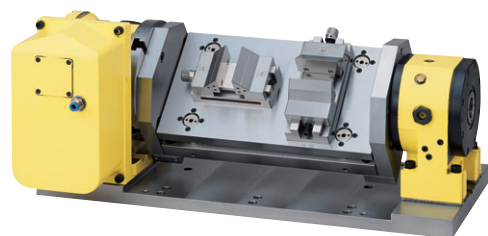

CNC180L & TAT105N-135 (Precision stock vice)

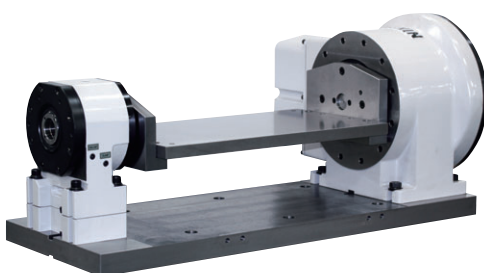

DD250LS-50 & TAT105N-135

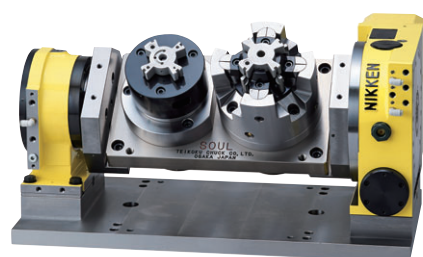

CNC205L & Support table (with power chuck)

ROTARY TABLE with DD MOTOR for *SPEEDIO* S500X1/S700X1



DD250LS-50

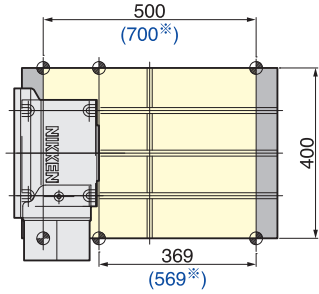

φ250mm ROTARY TABLE with DD MOTOR

- Diameter of Table : φ250mm (φ250mm sub table: Option)
- Spindle External Diameter : φ130mm
- MAX. Rotation Speed : 200min⁻¹
- Indexing Accuracy : 15sec.
- Brake Torque : 500Nm
- Net Weight : 75kg
- Servo Motor : DB23A053021W00
- Constant Torque : 50Nm
- MAX. Torque : 200Nm
- Spindle Hole : φ53mm_{H7} Through Hole

*The color of DD250L-50 is white as standard.

Optional Accessory:
φ250mm sub table
6 ports rotary joint

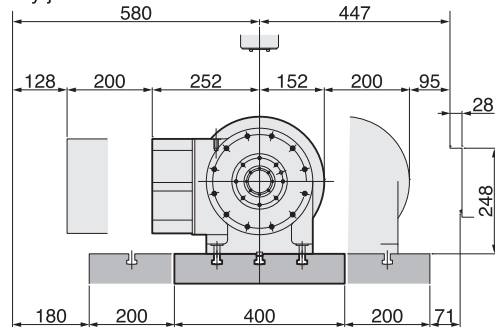
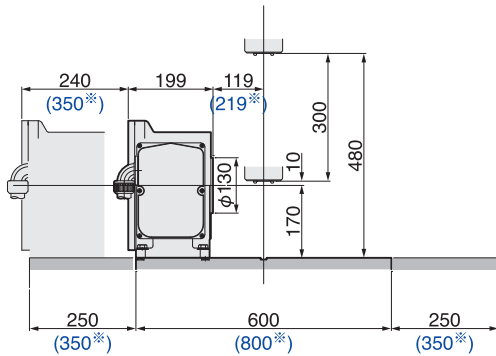

(*) The figures with blue color are the figures for S700X1.

DD250LS-50

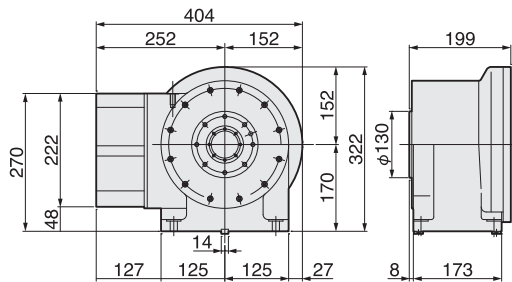

CNC ROTARY TABLE for CONVENTIONAL TYPE TAPPING CENTER



NIKKEN CNC rotary table is active in various brother machines. Please use NIKKEN CNC rotary table for *SPEEDIO* Series.

It is also possible to install on the existing machine, so please confirm machine model and stock situation, because the serve motor and the amplifier are different. P2.



5AX table on TC-22A



5AX table on TC-S2D



CNC table on TC-31A(pallet changer)+ work change by robot

S500X1
S700X1

CNC ROTARY TABLE for *SPEEDIO S1000X1*



CNC180LSA-BR2

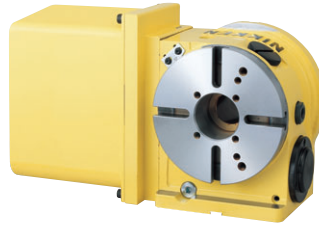

φ180mm type CNC ROTARY TABLE

- Diameter of Table :φ180mm
 - MAX. Work Load :100kg (Vertical) 200kg (Horizontal)
 - MAX. Rotation Speed :22.2 (min⁻¹), **44.4 (min⁻¹)*1**
 - Indexing Accuracy :±20sec.
 - Brake Torque :303Nm
 - Net Weight :48kg
 - Servo Motor :R2AAB8100HXPGA
 - Spindle Hole :φ60mmH7×φ40mm Through Hole
- *1:High speedio Z series.

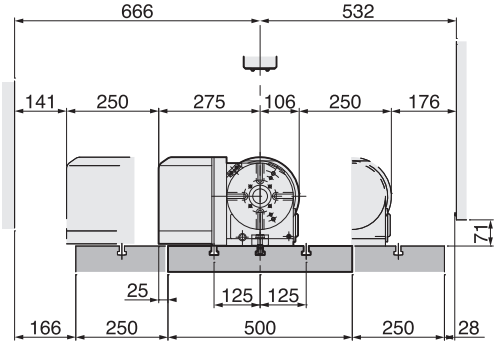
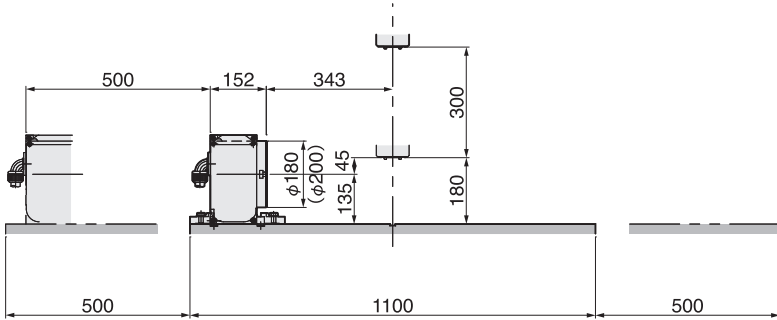
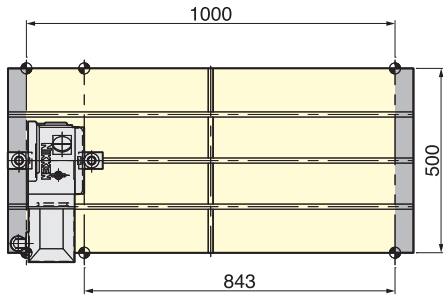

S1000X1

CNC180LSA-BR2 (TAT105N-135)

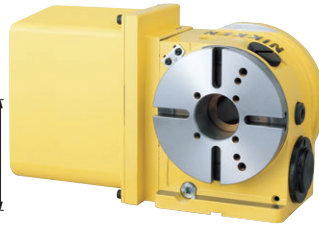

φ180mm type CNC ROTARY TABLE

- Diameter of Table :φ180mm
 - MAX. Work Load :100kg (Vertical) 200kg (Horizontal)
 - MAX. Rotation Speed :22.2 (min⁻¹), **44.4 (min⁻¹)*1**
 - Indexing Accuracy :±20sec.
 - Brake Torque :303Nm
 - Net Weight :48kg
 - Servo Motor :R2AAB8100HXPGA
 - Spindle Hole :φ60mmH7×φ40mm Through Hole
- *1:High speedio Z series.

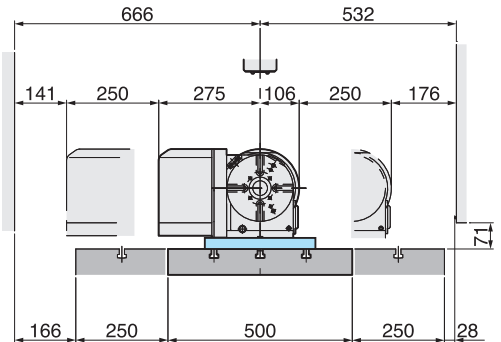
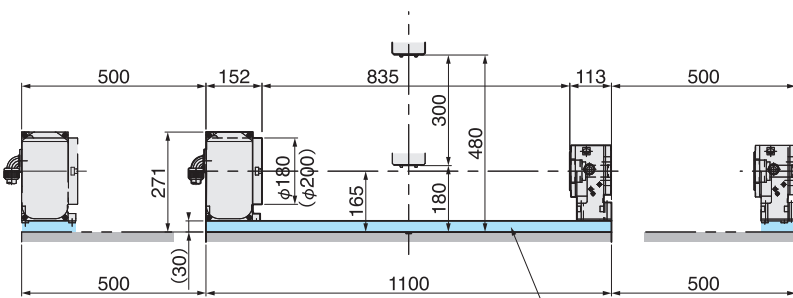
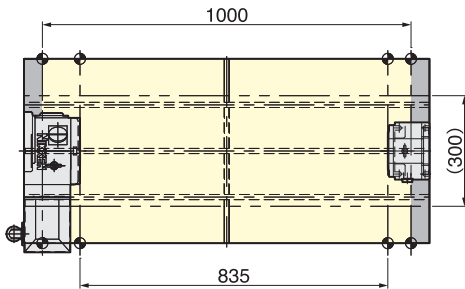

Please provide the plate by yourself.

CNC180LSA-BR2 CNC202LSA-BR2 is also available

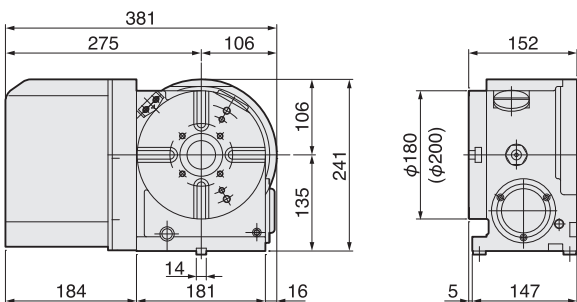

TAT105N-135

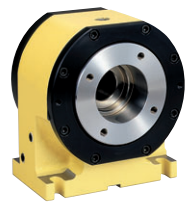
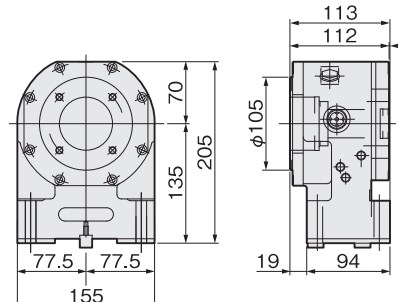

CNC ROTARY TABLE for *SPEEDIO S1000X1*



CNC260LSA-BR2

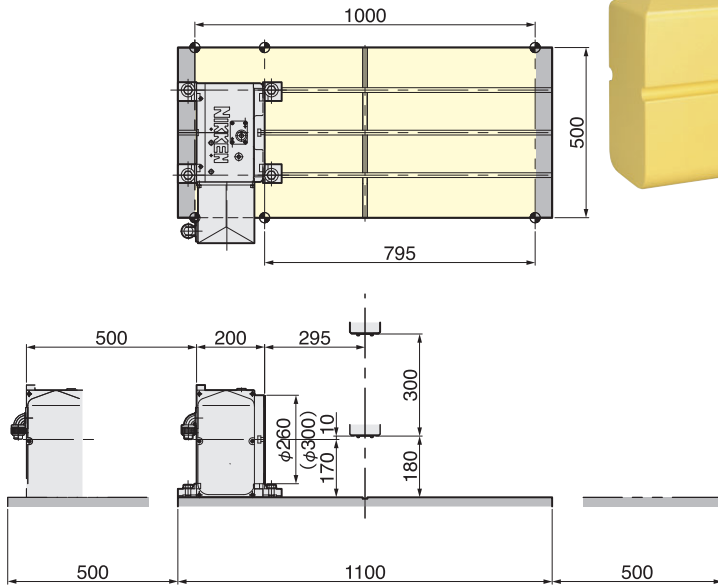

φ260mm type CNC ROTARY TABLE

- Diameter of Table :φ260mm
 - MAX. Work Load :300kg (Vertical) 150kg (Horizontal)
 - MAX. Rotation Speed :16.6 (min⁻¹), **33.3 (min⁻¹)*1**
 - Indexing Accuracy :±20sec.
 - Brake Torque :588Nm (Pneumatic), 1568Nm (Hydraulic)
 - Net Weight :120kg
 - Servo Motor :R2AAB8100HXPGA
 - Spindle Hole :φ80mmH7 Through Hole
- *1:High speedio Z series.

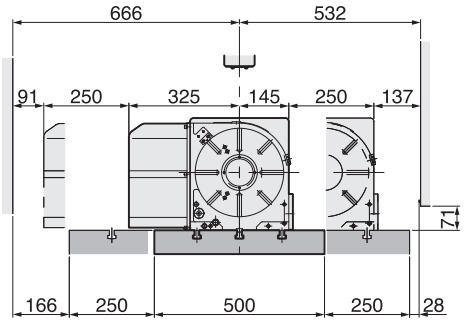

S-1000X1

CNC260LSA-BR2 (TAT250)

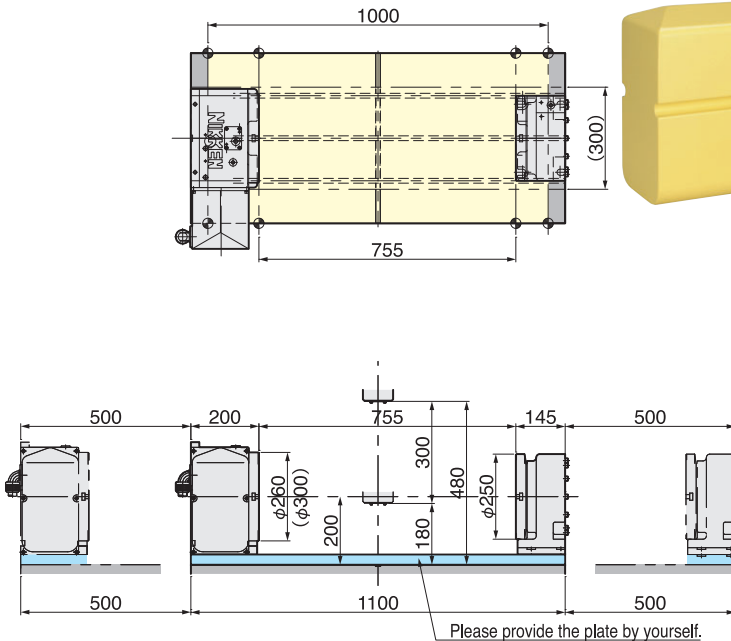

φ260mm type CNC ROTARY TABLE

- Diameter of Table :φ260mm
 - MAX. Work Load :300kg (Vertical) 150kg (Horizontal)
 - MAX. Rotation Speed :16.6 (min⁻¹), **33.3 (min⁻¹)*1**
 - Indexing Accuracy :±20sec.
 - Brake Torque :588Nm (Pneumatic), 1568Nm (Hydraulic)
 - Net Weight :120kg
 - Servo Motor :R2AAB8100HXPGA
 - Spindle Hole :φ80mmH7 Through Hole
- *1:High speedio Z series.

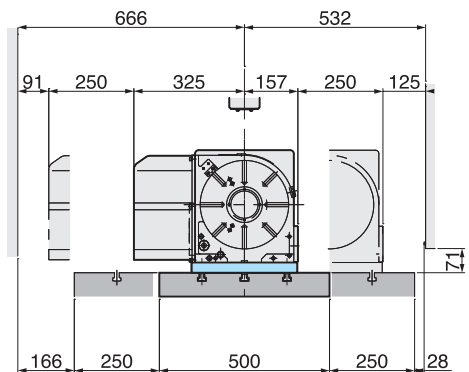

CNC260LSA-BR2 CNC302LSA-BR2 is also available.

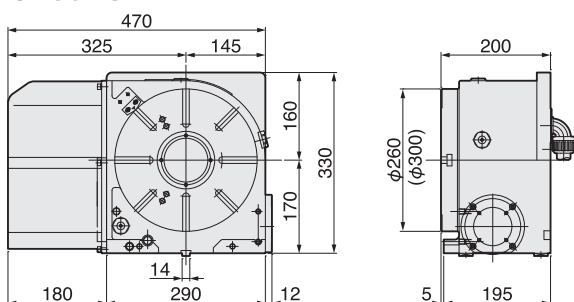

TAT250

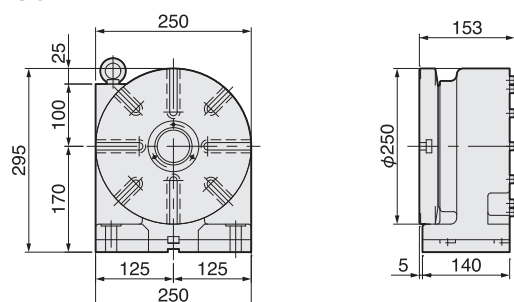

CNC ROTARY TABLE for *SPEEDIO S1000X1*



5AX-130SA-BR2



130mm type 5AX- TILTING ROTARY TABLE

- Diameter of Table : 130mm (With 130mm sub table)
- MAX. Work Load : 25kg (Vertical) 50kg (Horizontal)
- MAX. Rotation Speed : 22.2 (min⁻¹) (Rotary), 11.1 (min⁻¹) (Tilting)
- Indexing Accuracy : ±30sec. (Rotary), 60sec. (Tilting)
- Brake Torque : 205Nm (Rotary), 303Nm (Tilting)
- Net Weight : 115kg
- Servo Motor : R2AAB8100HXPGA (Rotary)
R2AAB8100HXPGA (Tilting)
- Spindle Hole : 60mm_{H7} × 30mm Through Hole
- Tilting Angle : 0° ~ 105°

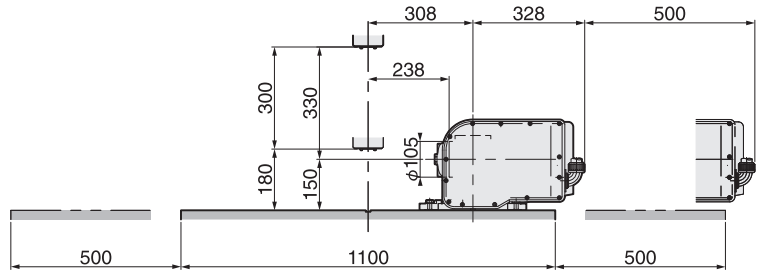
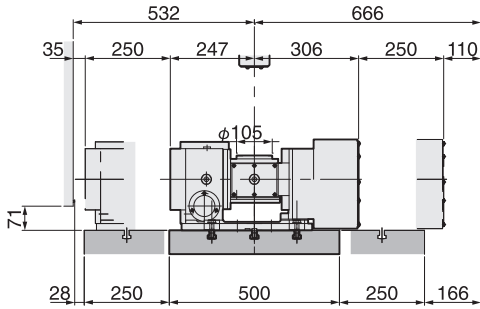
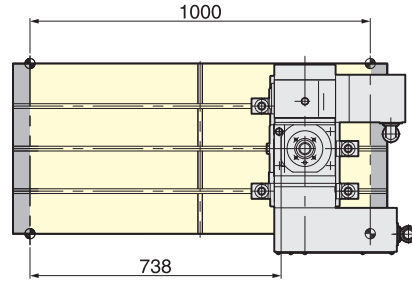

5AX-201SA-BR2

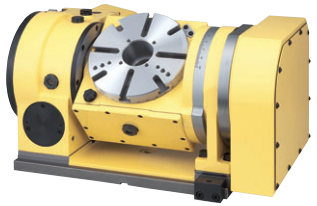

200mm type 5AX- TILTING ROTARY TABLE

- Diameter of Table : 200mm
- MAX. Work Load : 40kg (Vertical) 60kg (Horizontal)
- MAX. Rotation Speed : 22.2 (min⁻¹) (Rotary), 16.6 (min⁻¹) (Tilting)
- Indexing Accuracy : ±20sec. (Rotary), 60sec. (Tilting)
- Brake Torque : 588Nm (Rotary), 608Nm (Tilting) (Hydraulic)
303Nm (Rotary), 303Nm (Tilting) (Pneumatic)
- Net Weight : 160kg
- Servo Motor : R2AAB8100HXPGA (Rotary)
R2AAB8100HXPGA (Tilting)
- Spindle Hole : 60mm_{H7} × 50mm Through Hole
- Tilting Angle : 0° ~ 105°

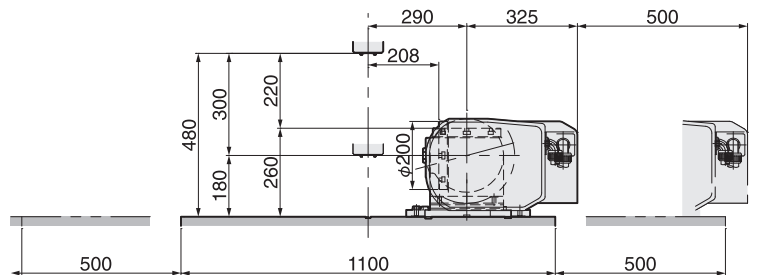
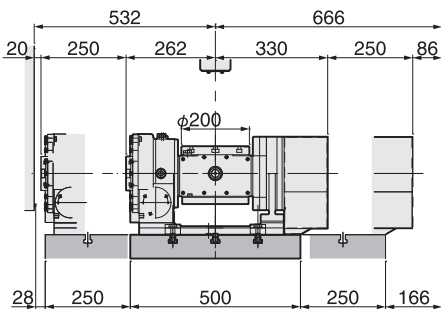
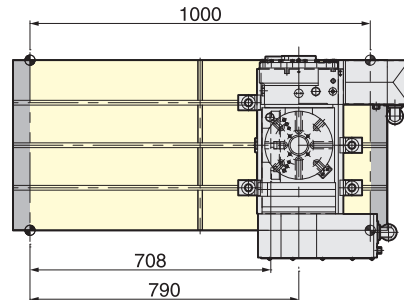

5AX-130SA-BR2

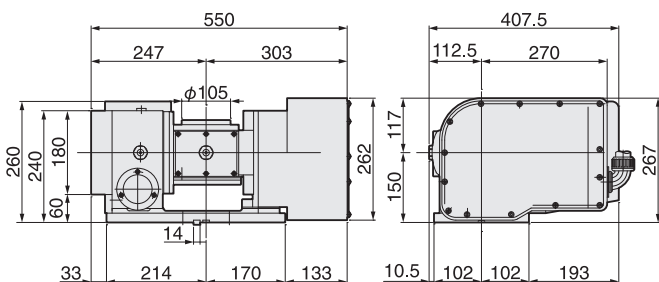

5AX-201SA-BR2

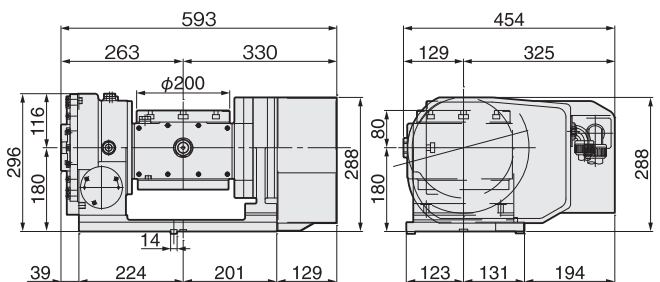

CNC ROTARY TABLE with DD MOTOR for SPEEDIO S1000X1



DD250LS-50

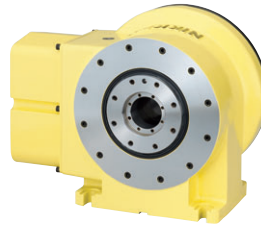

250mm ROTARY TABLE with DD MOTOR

- Diameter of Table : 250mm (250mm sub table: Option)
- Spindle External Diameter : 130mm
- MAX. Rotation Speed : 200min⁻¹
- Indexing Accuracy : 15sec.
- Brake Torque : 500Nm
- Net Weight : 75kg
- Servo Motor : DB23A053021W00
- Constant Torque : 50Nm
- MAX. Torque : 200Nm
- Spindle Hole : 53mm_{H7} Through Hole

*The color of DD250L-50 is white as standard.

Optional Accessory:
φ250mm sub table
6 ports rotary joint

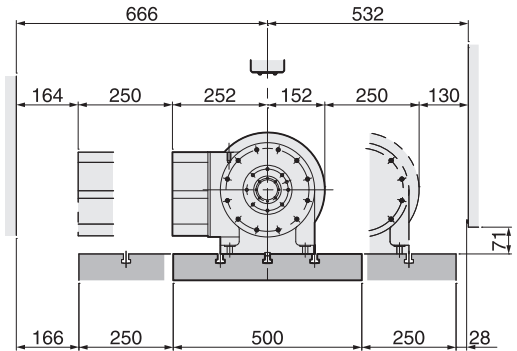
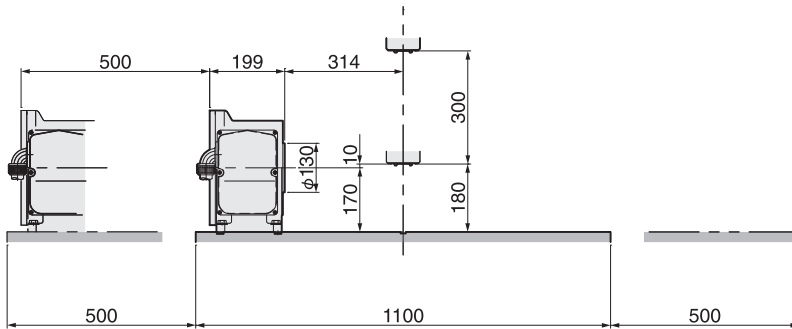
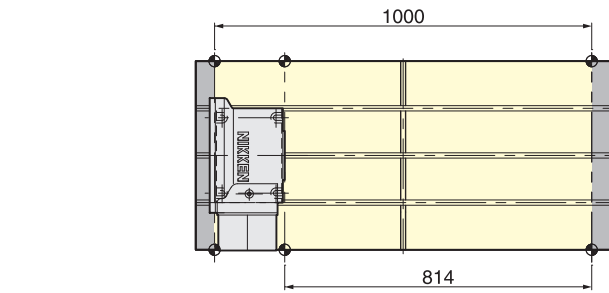

DD250LS-50

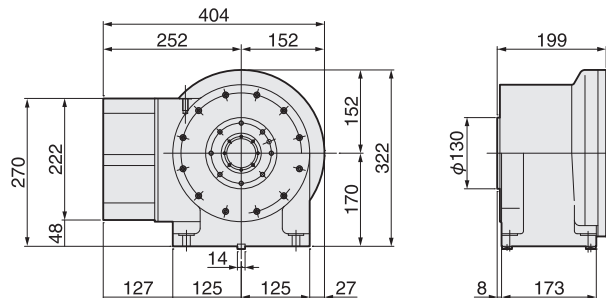

Special fitting metal is needed.

⚠ Caution

■ Selection of the CNC rotary table

- The support table is basically used in case of vertical application.
- The machining operation is generally light cut on aluminium materials, however, if the fixture or the component is large size, please make sure that the fixture inertia is within the MAX. work inertia.
- If the unbalance load is too big, it will affect on not only the indexing accuracy but also the durability. Please make sure the unbalance load will be within the following figures.
CNC105 : 10Nm, CNC180, 202 : 20Nm, CNC260, 302 : 30Nm
- In case of the unbalance load is large,
- The high speed Z series rotary table is not suitable, please use standard rotary table.
- Please installing the balance cylinder or counter balance.
- Please advise us the details of the component, fig fixture, indexing time etc. prior to your order, and we will make a calculation of the load and select the best suitable rotary table for your application.
- If the huge amount of coolant has to be applied, we could prepare air purge (with pneumatic pressure of 0.03MPa) on the CNC rotary table body as an option. Please contact us the details.

■ Check point for trunnion fixture

① When installing the table onto the sub-base, measure and check as follows.

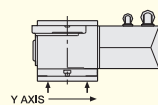

Parallelism between table & sub-base is recommended within 0.01mm

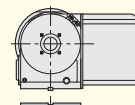

Difference between table centre and sub-base centre is recommended within 0.02mm

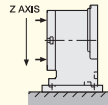

Squareness of table is recommended within 0.02mm

② Install the table & support table onto the M/C as follows.

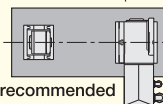

Centre lines are recommended within 0.02mm

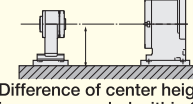

Difference of center height is recommended within 0.01mm

③ Trunnion fixture is recommended to be aligned as follows.

Squareness between center line & these faces is important

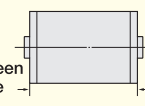

Centre of both side are recommended within 0.01mm



Squareness is important

CNC ROTARY TABLE for *SPEEDIO R450X1*



CNC105LSA-BR2

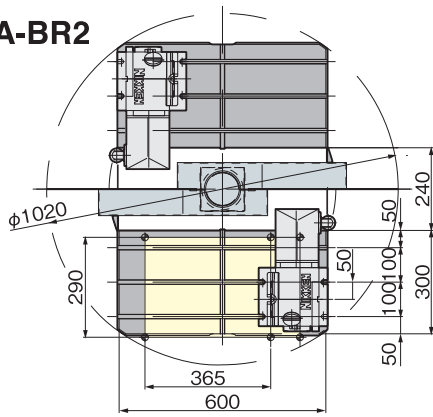

105mm type CNC ROTARY TABLE

- Diameter of Table : 105mm
- MAX. Work Load : 30kg
- MAX. Rotation Speed : 22.2 (min⁻¹), 44.4 (min⁻¹)*1
- Indexing Accuracy : ±20sec.
- Brake Torque : 205Nm
- Net Weight : 30kg
- Servo Motor : R2AAB8100HXPGA
- Spindle Hole : 60mm \varnothing ×30mm Through Hole

*1:High speedio Z series.

4 ports rotary joint (BROTHER's option)
Please order it to BROTHER, if required.

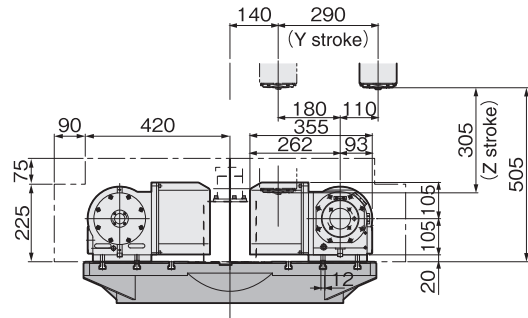
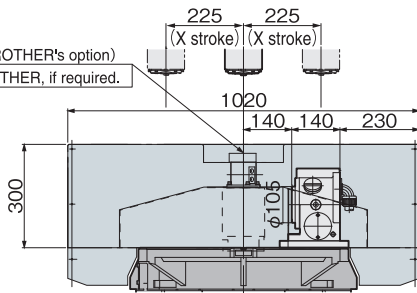

R450X1

CNC ROTARY TABLE for *SPEEDIO R450X1*



CNC180LSA-BR2

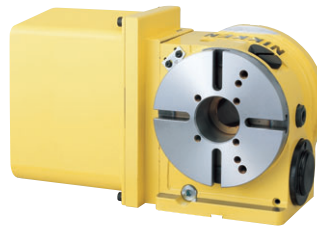
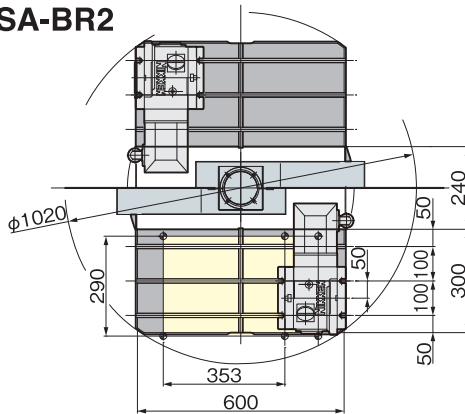

180mm type CNC ROTARY TABLE

- Diameter of Table : 180mm
- MAX. Work Load : 100kg (Vertical) 200kg (Horizontal)
- MAX. Rotation Speed : 22.2 (min⁻¹), 44.4 (min⁻¹)*1
- Indexing Accuracy : ±20sec.
- Brake Torque : 303Nm
- Net Weight : 48kg
- Servo Motor : R2AAB8100HXPGA
- Spindle Hole : 60mm \varnothing ×40mm Through Hole

*1:High speedio Z series.

4 ports rotary joint (BROTHER's option)
Please order it to BROTHER, if required.

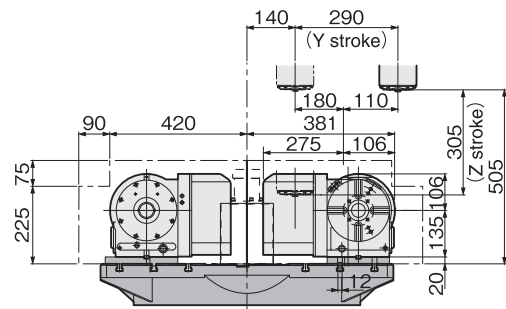
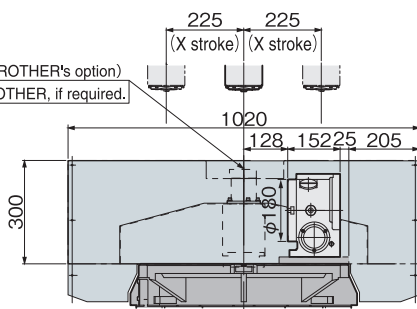

CNC105LSA-BR2

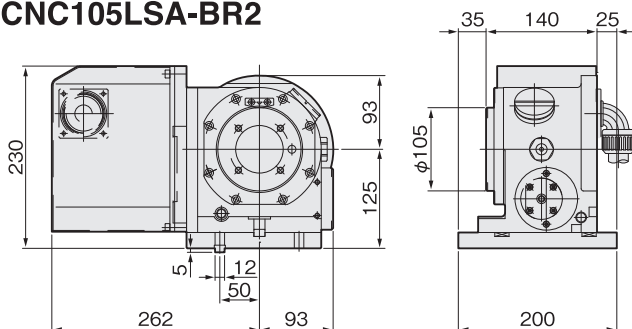

CNC180LSA-BR2 CNC202LSA-BR2 is also available

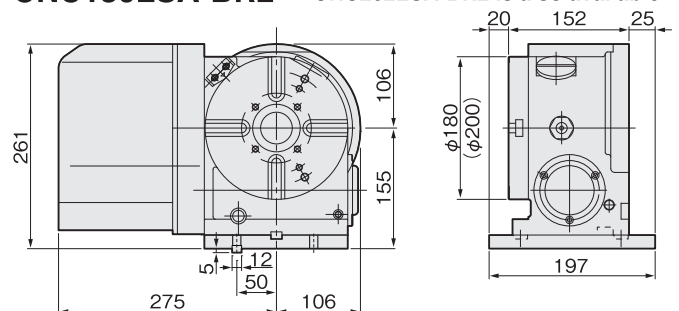

CNC ROTARY TABLE for SPEEDIO R450X1

NIKKEN

CNC205LSA-BR2(TAT105N-135)

NEW

200mm Slim type CNC ROTARY TABLE

- Diameter of Table : 200mm
 - MAX. Work Load :100kg (with supprt table)
 - MAX. Rotation Speed :22.2 (min⁻¹), 44.4 (min⁻¹)*1
 - Indexing Accuracy :±20sec.
 - Brake Torque :380Nm
 - Net Weight :45kg
 - Servo Motor :R2AAB8100HXPGA
 - 6 ports buit rotary joint can be fitted
- *1:High speedio Z series.

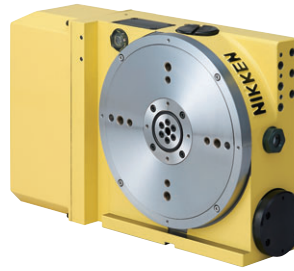
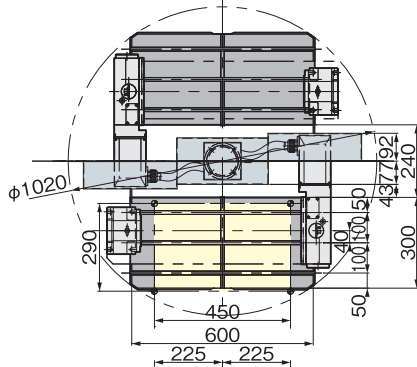

4 ports rotary joint (BROTHER's option)
Please order it to BROTHER, if required.

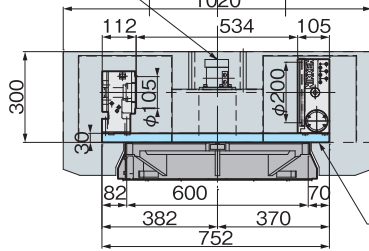

Please provide the plate by yourself.

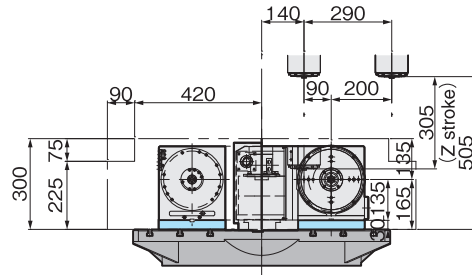

5AX- TILTING ROTARY TABLE for SPEEDIO R450X1

NIKKEN

5AX-130BASA-BR2

130mm type 5AX- TILTING ROTARY TABLE

- Diameter of Table : 130mm (With 130mm sub table)
 - MAX. Work Load :25kg (Vertical) 50kg (Horizontal)
 - MAX. Rotation Speed :22.2 (min⁻¹) (Rotary), 11.1 (min⁻¹) (Tilting)
 - Indexing Accuracy :±30sec. (Rotary), 60sec. (Tilting)
 - Brake Torque :205Nm (Rotary), 303Nm (Tilting)
 - Net Weight :115kg
 - Servo Motor :R2AAB8100HXPGA (Rotary)
R2AAB8100HXPGA (Tilting)
 - Spindle Hole : 60mmφ×30mm Through Hole
 - Tilting Angle :0°~105°
- *1:High speedio Z series.

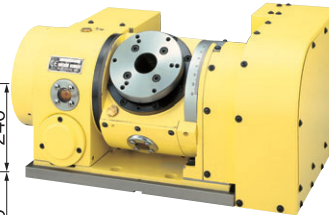
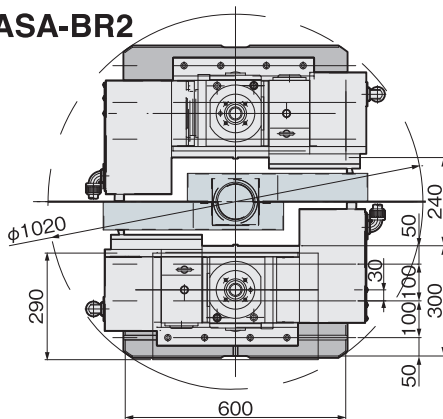

4 ports rotary joint (BROTHER's option)
Please order it to BROTHER, if required.

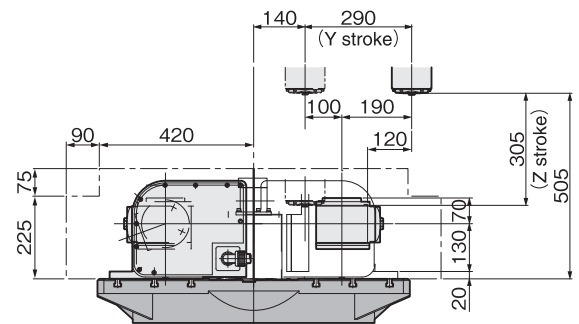
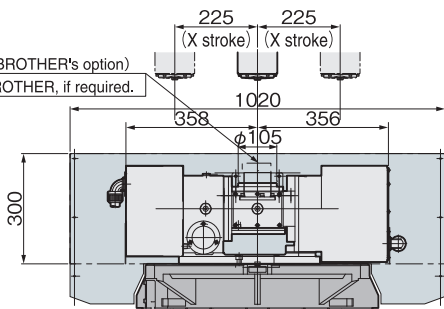

⚠ The previous agreement with BROTHER should be taken, when 2 set of 5AX-130 are installed.
The maxium load capacity of R450X1 should be changed to 200kg.

CNC205LSA-BR2

TAT105N-135

5AX-130BASA-BR2

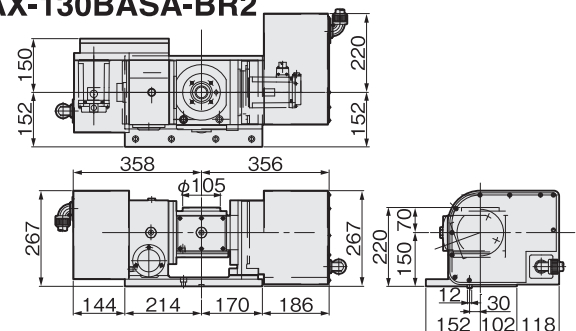
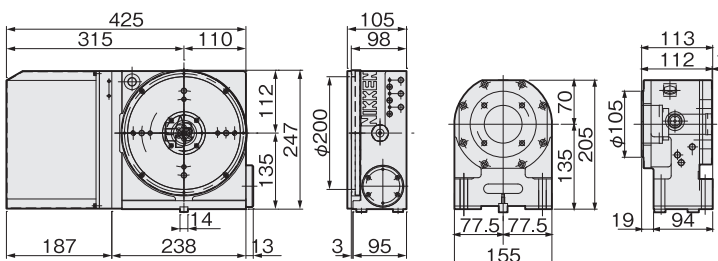

R450X1

CNC ROTARY TABLE for SPEEDIO R650X1



CNC105LSA-BR2

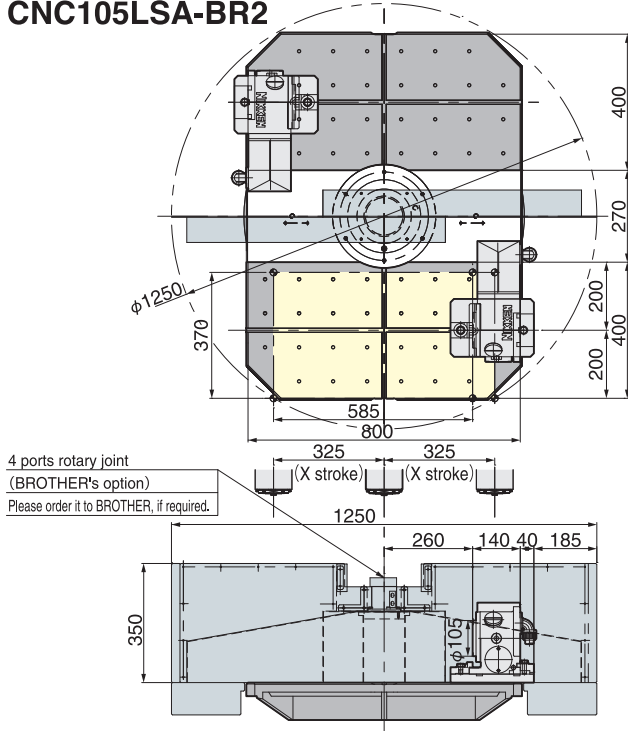

105mm type CNC ROTARY TABLE

- Diameter of Table : 105mm
- MAX. Work Load : 30kg
- MAX. Rotation Speed : 22.2 (min⁻¹), 44.4 (min⁻¹)*1
- Indexing Accuracy : ± 20 sec.
- Brake Torque : 205Nm
- Net Weight : 30kg
- Servo Motor : R2AAB8100HXPGA
- Spindle Hole : 60mm ϕ × 30mm Through Hole

*1: High speedio Z series.

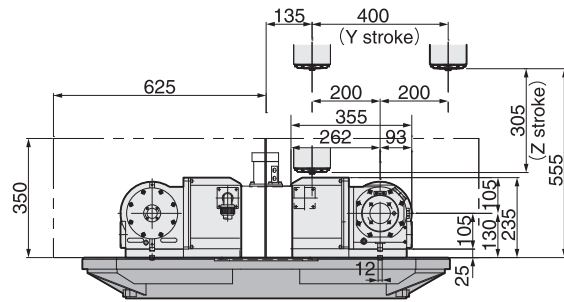

CNC180LSA-BR2

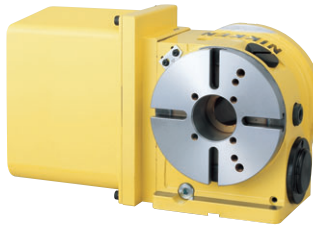
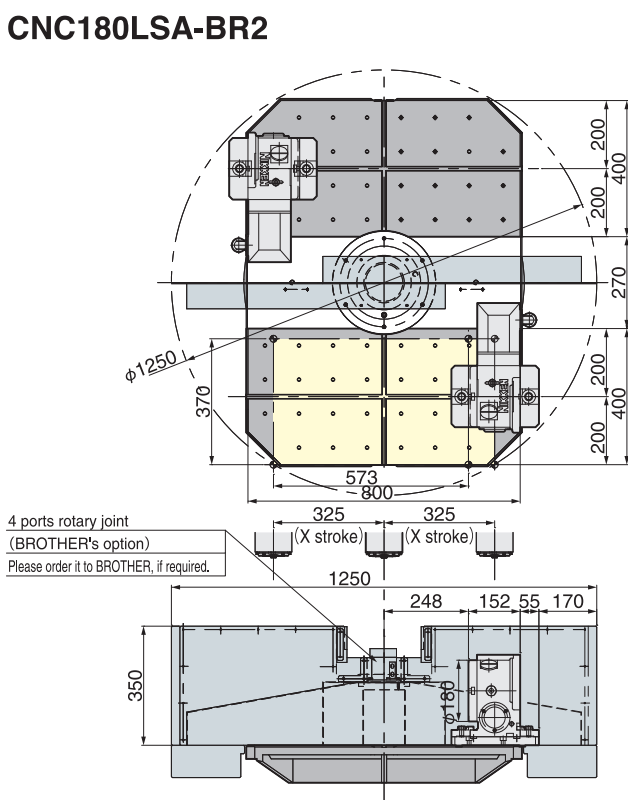

180mm type CNC ROTARY TABLE

- Diameter of Table : 180mm
- MAX. Work Load : 100kg (Vertical) 200kg (Horizontal)
- MAX. Rotation Speed : 22.2 (min⁻¹), 44.4 (min⁻¹)*1
- Indexing Accuracy : ± 20 sec.
- Brake Torque : 303Nm
- Net Weight : 48kg
- Servo Motor : R2AAB8100HXPGA
- Spindle Hole : 60mm ϕ × 40mm Through Hole

*1: High speedio Z series.

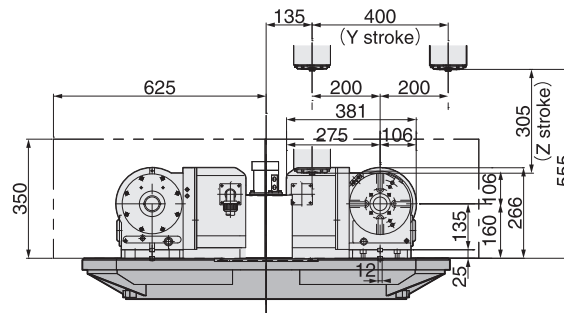

CNC105LSA-BR2

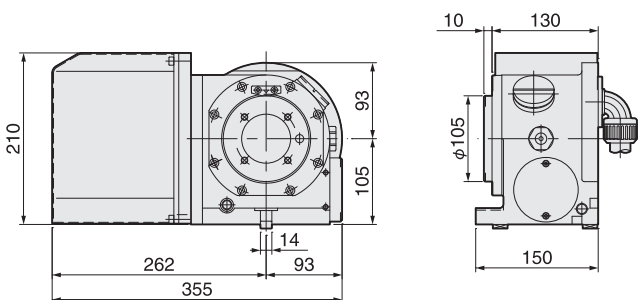

CNC180LSA-BR2 CNC202LSA-BR2 is also available

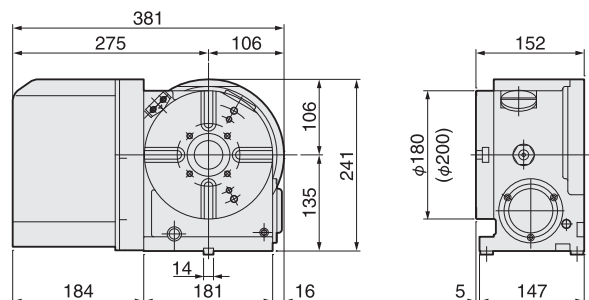

CNC ROTARY TABLE for *SPEEDIO R650X1*



CNC205LSA-BR2 (TAT105-135)

NEW

200mm Slim type CNC ROTARY TABLE

- Diameter of Table : 200mm
 - MAX. Work Load : 100kg (with supprt table)
 - MAX. Rotation Speed : 22.2 (min⁻¹), 44.4 (min⁻¹)*1
 - Indexing Accuracy : ±20sec.
 - Brake Torque : 380Nm
 - Net Weight : 45kg
 - Servo Motor : R2AAB8100HXPGA
 - 6 ports buit rotary joint can be fitted
- *1: High speedio Z series.

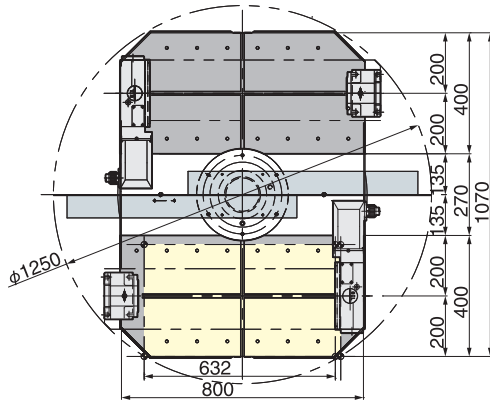

4 ports rotary joint
(BROTHER's option)
Please order it to BROTHER, if required.

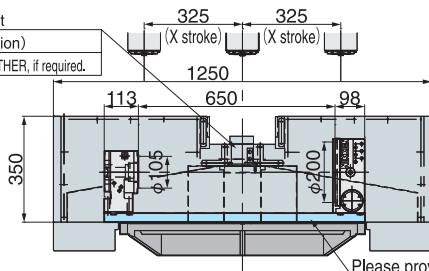

Please provide the plate by yourself.

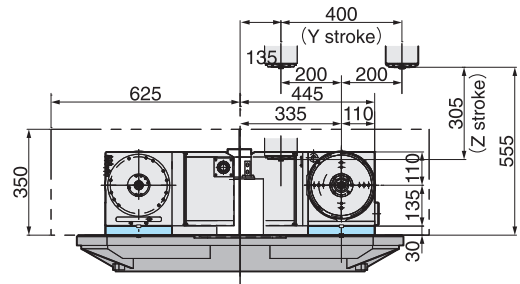

5AX- TILTING ROTARY TABLE for *SPEEDIO R650X1*



5AX-130BASA-BR2

130mm type 5AX- TILTING ROTARY TABLE

- Diameter of Table : 130mm (With 130mm sub table)
- MAX. Work Load : 25kg (Vertical) 50kg (Horizontal)
- MAX. Rotation Speed : 22.2 (min⁻¹) (Rotary), 11.1 (min⁻¹) (Tilting)
- Indexing Accuracy : ±30sec. (Rotary), 60sec. (Tilting)
- Brake Torque : 205Nm (Rotary), 303Nm (Tilting)
- Net Weight : 115kg
- Servo Motor : R2AAB8100HXPGA (Rotary)
R2AAB8100HXPGA (Tilting)
- Spindle Hole : 60mm \pm 7 \times 30mm Through Hole
- Tilting Angle : 0° ~ 105°

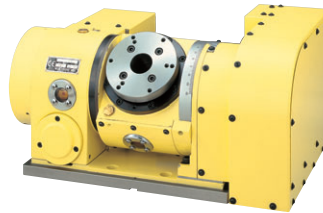
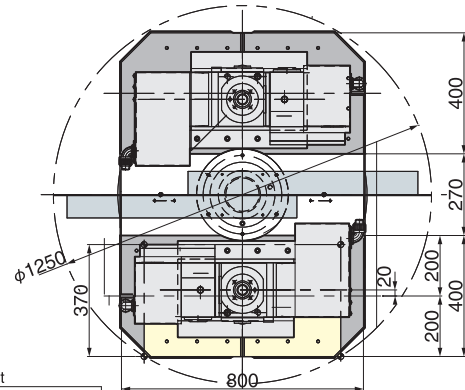

4 ports rotary joint
(BROTHER's option)
Please order it to BROTHER, if required.

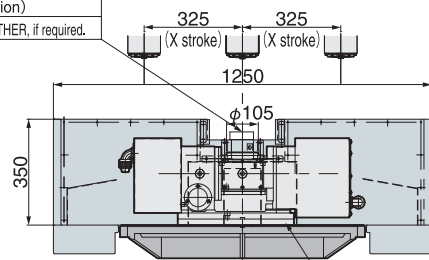

Mounting Base is needed.

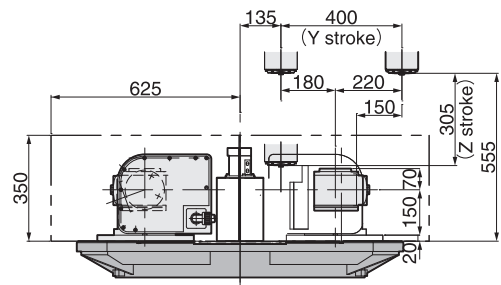

The previous agreement with BROTHER should be taken, when 2 set of 5AX-130 are installed.

CNC205LSA-BR2

TAT105-135

5AX-130BASA-BR2

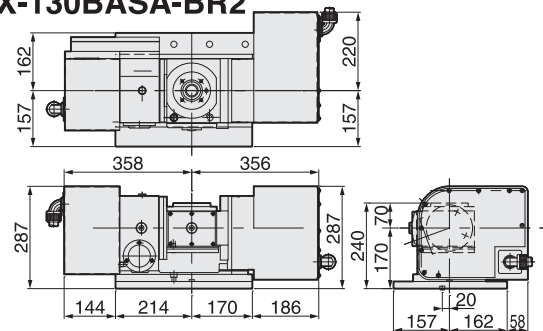
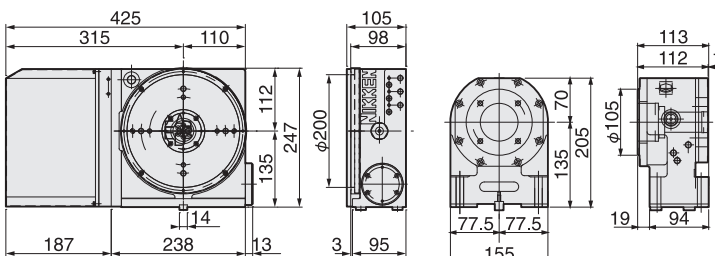

DD moter table is also possible to install to R650X1. Please contact us.

R650X1

TAILSTOCK, SUPPORT TABLE



List of Tailstock and Support Table

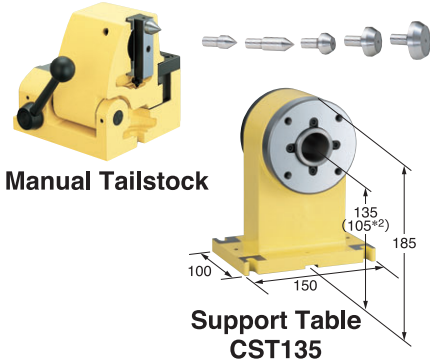
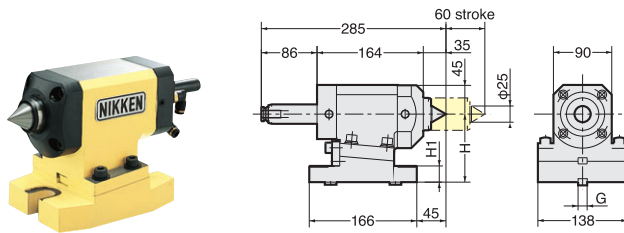

Table Model	Centre Height	Manual	Air/Hyd.	Support Table	
		Stroke:15mm	Stroke:60mm	CST without Brake	TAT with Brake
CNC105L	105	P-105SL	PBA-105	CST105	TAT105
CNC180L, 202L, 205L	135	P-125SL	PBA-135	CST135	TAT170
CNC260L, 302L, DD250LS	170	P-170SL	PBA-170	*1	TAT250
5AX-130	150	P-150S*3	PBA-150		—
5AX-201	180	P-170S*3	PBA-180		

- *1 The center height can be adjusted to the CNC rotary table by the base plate.
- *2 Center height of CST105
- *3 5 pcs of the changable center are attached as standard for P-150S, P-170S.
- *3 The left-handed type is also available.

Air/Hyd. both usable Tailstock



Code No.	Center Height H	H1	G	Thrust (N)		Weight (kg)
				Air 0.5MPa	Hyd. 2MPa	
PBA-105	105	25	14	1176	4733	15
PBA-135	135	55	14	1176	4733	20
PBA-150	150	70	18	1176	4733	22
PBA-170	170	90	18	1176	4733	24.5

- * Rotary center is built-in.
- * MT (Morse Taper) type quill is also available. Please contact us.
- * The different length of the stroke is available. Please contact us.
- * Center height can be adjusted within 0.35mm.

Support Table

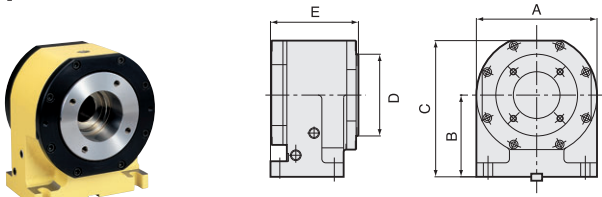

Photo. shows TAT105N.

Air ports are 2 X Rc1/8. Solenoid valve and clamp/unclamp confirmation switches are not included.

Code No.	A	B	C	D	E	Clamping System	Brake Torque (N·m)	Weight (kg)
TAT170N	155	135	220	170	138	Air	205	25
TAT250	250	170	295	250	145	Air/Hyd.	112/784	50

- * Air pressure is 0.5MPa.
- * The powerful double intensifying brake system is built in TAT105 and TAT170.
- * Rotary joint is available for all models.
- * Please contact us for TAT250.

ROTARY JOINT, SPECIAL COLOR



Rotary Joint

There are 2 types of the rotary joint such as cylinder type and flange plate type. Rotary joint is used for clamp/unclamp of the work piece, confirmation of proper clamp, cleaning, coolant etc. The fine cutting swarf may come into the coolant port through the filter, therefore the coolant port is recommended to be separated.

1. Cylinder type Rotary Joint 2. Flange Plate type Rotary Joint

Retrofitting to standard CNC rotary table is available.

IN port position can be changed at any angle of 360°. Any position, which causes no interference against M/C, can be selected.

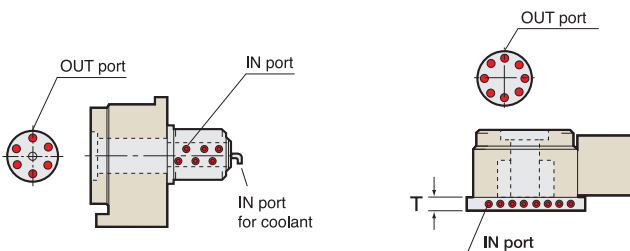

Code No.	Cylinder type	Flange Plate type	
	MAX. No. of Ports	MAX. No. of Ports	T mm
CNC105L	4+1*1	4	25
180L, 202L	6+1*1	4	25
260L	8+1*1	6	30
5AX-130	2(4)	—	—
5AX-201	—	4	—
DD250LS	6	6	30

() : MAX. port number of high column table
* : +1 port is the port located in the center hole (for coolant)

Caution of IN port

- When the air is supplied for all IN ports, please contact us.
- Please do not supply the different pressure of the air in the IN ports next each other.
- Please make sure that the line filter should be provided for pneumatic supply use in order to avoid swarf and water ingress for all models.
- This is not avoidable that the oil of the hydraulic port may be leaked to the next air port for the long time use, due to the characteristic of the seal. Please do not assign the air port next to the hydraulic port as much as possible.
- The rotary joint must be specially treated to prevent from the rust, when using the glycol solution for the operating fluid. Please inform us when ordering.
- When the rotary joint is designed at your side, please select the low friction type seal. Then, please check the rotary table movement after installation of your rotary joint, not to over load.

Special Color

Please order with the color sample of Munsell Color No.

ACCURACY STANDARD



CNC Rotary Table

No.	Measuring Item	Measuring Method	CNC105	CNC180 202	CNC205	CNC260 302	DD250LS
1	Parallelism between table surface and frame bottom surface (Concave)		0.015 mm	0.015 mm		0.02mm	
2	Runout of table surface		0.01 mm	0.01 mm	0.01 mm	0.015mm	0.01 mm
3	Concentricity of centre bore		0.01 mm	0.01 mm	0.01 mm	0.01 mm	0.01 mm
4	Squareness of table surface (Minus deviation at upper part is not permitted.)		0.020 mm	0.02 mm	0.02mm	0.02 mm	0.01 mm
5	Parallelism between centreline of test bar and key way		0.020 mm	0.02 mm	0.02mm	0.02mm	At 150mm 0.02 mm
6	Parallelism between frame bottom surface and table centre line		0.020 mm	0.02 mm	0.02mm	0.02 mm	At 150mm 0.02 mm
7	Indexing accuracy		±30"	±20"	±20"	20"	15"
8	Repeatability		4"	4"	4"	4"	4"

★For ultra precision option: One rank higher accuracies than the above figures are inspected.

5AX- Tilting Rotary Table

No.	Measuring Item	Measuring Method	5AX-130	5AX-201
1	Parallelism between table surface and frame bottom at tilting angle 0° (Concave)		0.015 mm	0.015 mm
2	Deviation of table surface at tilting angle 0°		0.01 mm	0.01 mm
3	Deviation of table centre hole at tilting angle 0°		0.01 mm	0.01 mm
4	Deviation of table centre hole at tilting angle 0°		0.02 mm	0.02 mm
5	Parallelism between table surface and centre line of guide key at tilting angle 90°		0.015 mm	0.015 mm
6	Displacement of centre when moving from 0° to 90° at tilting angle 90°		0.01 mm	0.015 mm
7	Indexing accuracy of rotary axis		±30"	20"
8	Repeatability of rotary axis		4"	4"
9	Indexing accuracy of tilting axis	Cumulative	60"	60"
10	Repeatability of tilting axis		±6"	±6"

★For ultra precision option: One rank higher accuracies than the above figures are inspected.

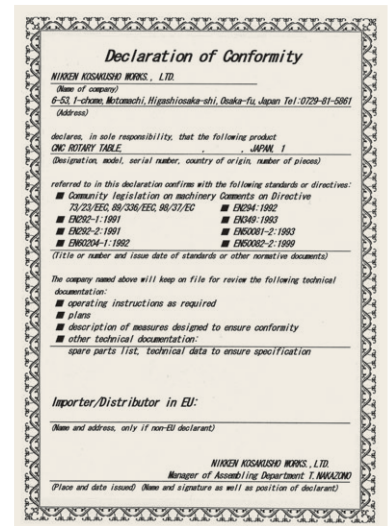

CE Mark Declaration of Conformity

CNC ROTARY TABLE with CONTROLLER



CNC rotary table with Alpha 21 controller can be used for the tapping center without additional axis.

■ Single M signal provides various automatic operation.

■ The latest designed digital servo system.

The dimension of the servo motor became more compact and the torque is powered up.

■ More than 25,000 sets working in the field.

α21 controller

· Standard (400W, 750W)

300×280×285 10kg

Single phase AC200/220V



SLIM CHUCK

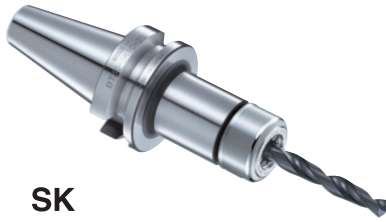

SK

Photo. shows High Speed Tooling.

Code No.	Gripping Range ϕ D	Nose Dia. ϕ C	L
BT30-SK 6- 60P, 90P, 120P	0.7 ~ 6.0	19.5	60, 90, 120
-SK10- 45P, 60P, 75P, 90P, 120P	1.75 ~ 10.0	27.5	45, 60, 75, 90, 120
-SK13- 60P, 75P, 90P, 120P	2.75 ~ 13.0	33	60, 75, 90, 120
-SK16- 60P, 75P, 90P, 120P	2.75 ~ 16.0	40	
-SK20- 60P, 75P, 90P	3.5 ~ 20.0	48.5	60, 75, 90
-SK25- 90P	7.5 ~ 25.4	55	90

★This table is for high speed tooling. Please specify the Code No. without "P" for standard tooling. eg. BT30-SK10-60
 ★Please add "C" in the Code No. of standard slim chuck for high pressure center through coolant. eg. BT30-SK10C-60

★2Lock (NBT30) is also available. 2Lock is for high pressure center through coolant (MAX. 7MPa). eg. NBT30-SK10C-60P
 ★Collet, Adjust screw and the GH handle (spanner) are available as an option.

SLIM COLLET



SK

SK Collet Code No.
SK 6- 0.8, 1, 1.25, 1.5, 1.75, 2, 2.25, 2.5, 2.75, 3, 3.175 , 3.5, 4, 4.5, 5, 5.5, 6
SK 10- 2, 2.25, 2.5, 2.75, 3, 3.175 , 3.5, 4, 4.5, 5, 5.5, 6, 6.5, 7, 7.5, 8, 8.5, 9, 9.5, 10
SK 13- 3, 3.5, 4, 4.5, 5, 5.5, 6, 6.5, 7, 7.5, 8, 8.5, 9, 9.5, 10, 10.5, 11, 11.5, 12, 12.5, 13
SK 16- 3, 3.5, 4, 4.5, 5, 5.5, 6, 6.5, 7, 7.5, 8, 8.5, 9, 9.5, 10, 10.5, 11, 11.5, 12, 12.5, 13, 13.5, 14, 14.5, 15, 15.5, 16
SK 20- 4, 4.5, 5, 5.5, 6, 6.5, 7, 7.5, 8, 8.5, 9, 9.5, 10, 10.5, 11, 11.5, 12, 12.5, 13, 13.5, 14, 15, 16, 17, 18, 19, 20
SK 25- 8, 10, 12, 16, 16.5, 17, 17.5, 18, 18.5, 19, 19.5, 20, 20.5, 21, 21.5, 22, 22.5, 23, 23.5, 24, 24.5, 25

★SK6-0.8 ~ SK6-1: The gripping range is 0.1mm.
 SK6-1.5 ~ SK6-3: The gripping range is 0.2mm.
 SK10-2 ~ SK10-3 < SK13-3, SK16-3: The gripping range is 0.25mm.
 The gripping range of the other collets is 0.5mm.

★"P" class collet of run-out accuracy 3 μ m is also available. eg. SK10-3P
 ★"A" type collet with bold character (gripping range: h8) is also available. eg. SK10-3A

MILLING CHUCK



C

Photo. shows High Speed Tooling.

Code No.	Gripping Range ϕ D	Nose Dia. ϕ C	L	Insert Length ℓ
BT30-C12- 55G	12	33	58	58
-C16- 55G	16	40	57	65
-C20- 75G	20	48	75	80
-C25- 75G*1, 80G	25	55	75*1, 82	68, 68
-C32- 90G*2, 100G	32	62	90*2, 100	68, 76

★This table is for high speed tooling. Please specify the Code No. without "G" for standard tooling. eg. BT30-C20-75

★2Lock (NBT30) is also available. 2Lock is for high pressure center through coolant (MAX. 7MPa). eg. BT30-C20-75
 ★GH handle (spanner) are available as an option.



*1 BT30-C25-75G can not be used for the tapping center with ATC arm (TC-22B, -32BNFT, -32BNQT) due to collision. Please use BT30-C25-80G instead.
 *2 NK collet can not be used on BT30-C32-90G, please use KM collet. NK collet can be used on BT30-C32-100G.

STRAIGHT COLLET

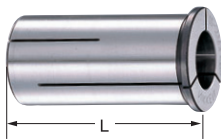

KM

Photo. shows ANNIVERSARY type KM Collet.

KM Collet Code No. (OD-ID)
KM12-2, 3, 4, 5, 6, 7, 8, 9, 10
KM16-2, 3, 4, 5, 6, 7, 8, 9, 10, 11, 12
KM20-2, 3, 4, 5, 6, 7, 8, 9, 10, 11, 12, 13, 14, 15, 16
KM22-3, 4, 5, 6, 7, 8, 9, 10, 11, 12, 13, 14, 15, 16, 17, 18, 19, 20
KM25-3, 4, 5, 6, 7, 8, 9, 10, 11, 12, 13, 14, 15, 16, 17, 18, 19, 20, 21, 22
KM32-3, 4, 5, 6, 7, 8, 9, 10, 11, 12, 13, 14, 15, 16, 17, 18, 19, 20, 21, 22, 23, 24, 25, 26

★[For synchronous tapping], collet with special ID (5.5, 6.2, 8.5, 10.5, 12.5) is available.
 ★The collets with bold character are "ANNIVERSARY" type KM Collet.
 ★Please note the acceptable shank tolerance is h6 ~ h7.
 ★Collet removal (9CKR) is available as an option.



GH HANDLE for HIGH SPEED TOOLING



Torque adjustable GH Handle

GH

Code No.	Milling Chuck	Slim Chuck	MAJOR DREAM
GH 6*	—	SK 6-P / SKT 6	MDSK 6
GH10*	—	SK10-P / SKT10	MDSK10
GH12*	C12-G	SK13-P / SKT13	MDSK13
GH16*	C16-G	SK16-P / SKT16	MDSK16
GH20*	C20-G	SK20-P / SKT20	MDSK20
GH25*	C25-G	SK25-P / SKT25	MDSK25
GH32S	C32-G (Nose Ring: ϕ 62mm)	—	—

★Torque adjustable GH Handle is available for GH Handle marked *. eg. CH6-TLS, GH10-TLS, GH12-TLS, GH16-TLS, GH20-TLS, GH25-TLS



MAJOR DREAM HOLDER



MDSK

Code No.	Gripping Range ϕ D	Nose Dia. ϕ C	L
NBT30-MDSK 6- 50, 60, 75, 90	3.0~ 6.0	19.5	50, 60, 75, 90
-MDSK10- 50, 60, 75, 90	3.0~10.0	27.5	
-MDSK13- 60, 75, 90	3.0~13.0	33	60, 75, 90
-MDSK16- 75, 90	3.0~16.0	40	75, 90

- ★2LOCK is applied for MAJOR DREAM HOLDER.
- ★Please add "P" at the end of Code No. for high speed tooling. eg. NBT30-MDSK10-60P
- ★Holder with an adjust screw for axial adjustment is available as an option. Please contact us.
- ★Please use A type SK collet for end mill operation.

High Speed MAJOR DREAM HOLDER

Code No.	MAX. min ⁻¹
NBT30-MDSK 6- P	30,000
-MDSK10- P	
-MDSK13- P	
-MDSK16- P	25,000

MAJOR DREAM PRO-ENDMILL



MDPE

Code No.	D	No. of Teeth	L	Arbor Code No.	Head Code No.
NBT30-MDPE16- 75	16	2	75	NBT30-MDPE-M 8- 45	M 8-MDPE16-30
-MDPE20- 75	20	3		-MDPE-M10- 45	M10-MDPE20-30
-MDPE25- 80	25	2	80	-MDPE-M12- 45	M12-MDPE25-35
-MDPE32- 95	32	3	95	-MDPE-M16- 55	M16-MDPE32-40

★2LOCK is applied for MAJOR DREAM PRO-ENDMILL.



ϕ D	Code No.	OD ϕ d	Screw G	MAX. Depth	No. of Teeth
16	M 8-MDPE16-30	8.5	M 8	10	2
20	M10-MDPE20-30	10.5	M10		3
25	M12-MDPE25-35	12.5	M12	15	2
32	M16-MDPE32-40	17.0	M16		3

★The insert tip is available as an option.
 ϕ 16, ϕ 20 : AOMT123608PEER-M, ϕ 25, ϕ 32 : AOMT184808PEER-M

ZERO FIT TYPE SLIM CHUCK



SZF

MAX. run-out at 100mm	
SZF 6	0.050mm/dia.
SZF10	0.050mm/dia.
SZF16	0.040mm/dia.

ϕ 0.7~ ϕ 16

Code No.	Gripping Range ϕ D	Nose Dia. ϕ C	L
BT30-SZF 6- 90	0.7 ~ 6.0	19.5	90
-SZF10- 90	1.75~10.0	27.5	
-SZF16-105	2.75~16.0	40	

★2Lock (NBT30) is also available. 2Lock is for high pressure center through coolant (MAX. 7MPa).
 eg. NBT30-SZF10C-90

★Wrench to adjust run-out (9ZF) is available as an option.



Wrench to adjust 9ZF

ZERO FIT TYPE MILLING CHUCK

ϕ 20, ϕ 25

Code No.	Gripping Range ϕ D	Nose Dia. ϕ C	L
BT30-CZF20-100	20	51.5	100
-CZF25-100	25	59.5	

MAX. run-out at 100mm	
CZF20	0.050mm/dia.
CZF25	0.050mm/dia.

FACE MILL ARBOR



FMA
FMC

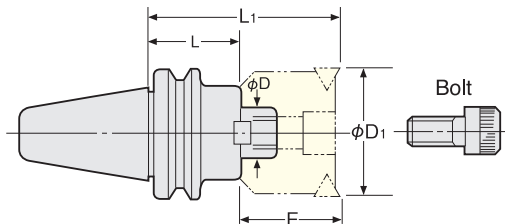

Code No.	D	L	Dimensions of Arbor with Cutter			
			L1	D1	F	Bolt
BT30-FMA25.4- 45	25.4	45	95	80	50	FM12
-FMC22 - 40	22	40	80	50	40	M10 × 30

★2Lock (NBT30) is also available. eg. NBT30-FMA25.4-45

PULL STUD



Without Hole: PS-17
 With Hole: PS-130E



Please refer NC TOTAL TOOLING SYSTEM catalogue for more detail.

TURNING TOOL for SPEEDIO M140X1



ROUND BYTE HOLDER (φ20mm)

BT30-BHC20-38

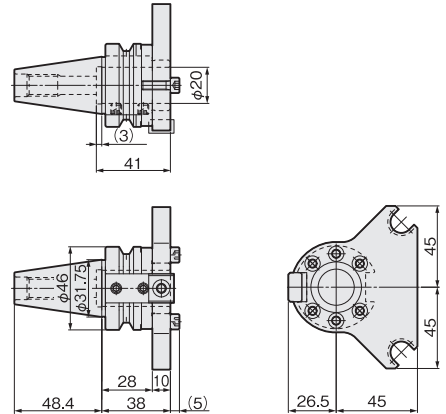
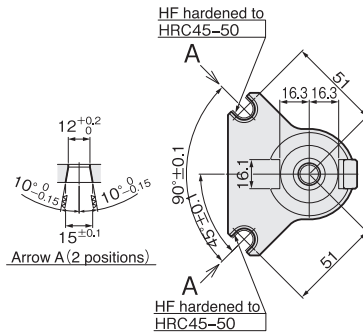
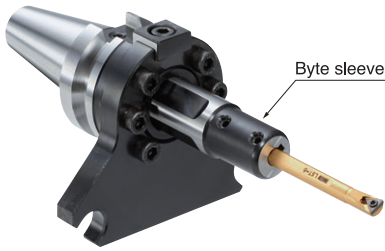

Byte Sleeve

without Hole

Code No. d-D	C	L1	L2	ℓ	G
LEA20S- 6	18	26	41	32-67	9SLG5P0.5-5
- 8	19.5			36-67	9SLG6P0.75-6
-10	27	10		45-67	M6-8L
-16	24.5	35		30	9SLG6P0.75-5

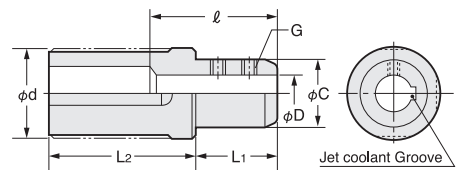

LEA

with Hole

Code No. d-D	C	L1	L2	ℓ	G
LEA20S-6C	18	26	41	32	9SLG5P0.5-5
-8C	19.5			36	9SLG6P0.75-6
-10C	27	10		45	M6-8L
-16C	24.5	35		30	9SLG6P0.75-5

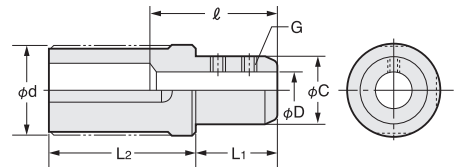

SQUARE BYTE HOLDER (□20mm)

BT30-BHS20-96

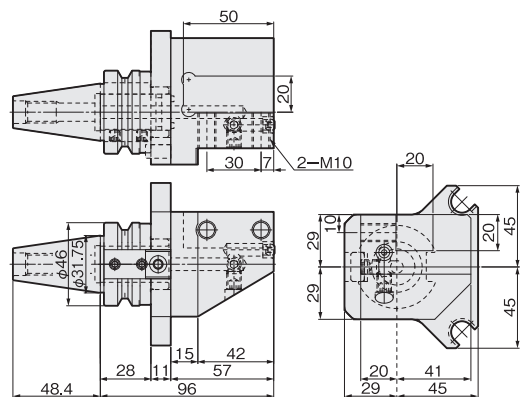
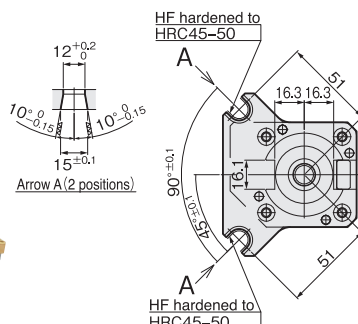
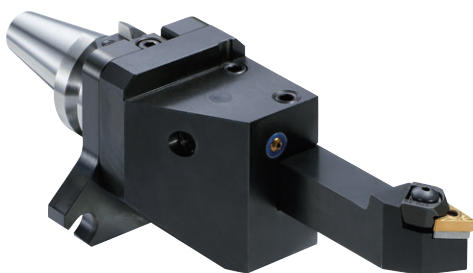

BT30-BHSH20-79

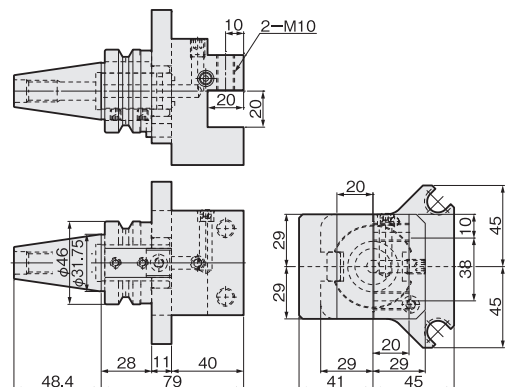
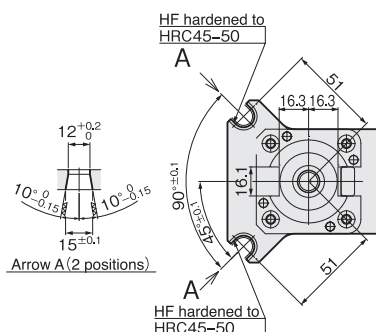
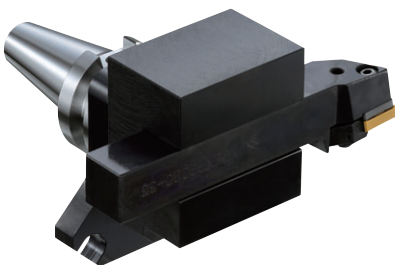

NIKKEN WORLD WIDE SALES BRANCH



There are overseas Sales Branches in 14 countries. Each sales branch has stocks for toolings and CNC Rotary Tables, and service engineers look after the maintenance and service operation of our products. In the other region, e.g. East-South Asia, Ozaena, South America, Africa, etc., there are some distributors. At the production line in abroad, as there are many requirements for special tools and CNC Rotary Table to suit the special specifications, please ask us or distributors for spare tools and maintenance parts in advance.

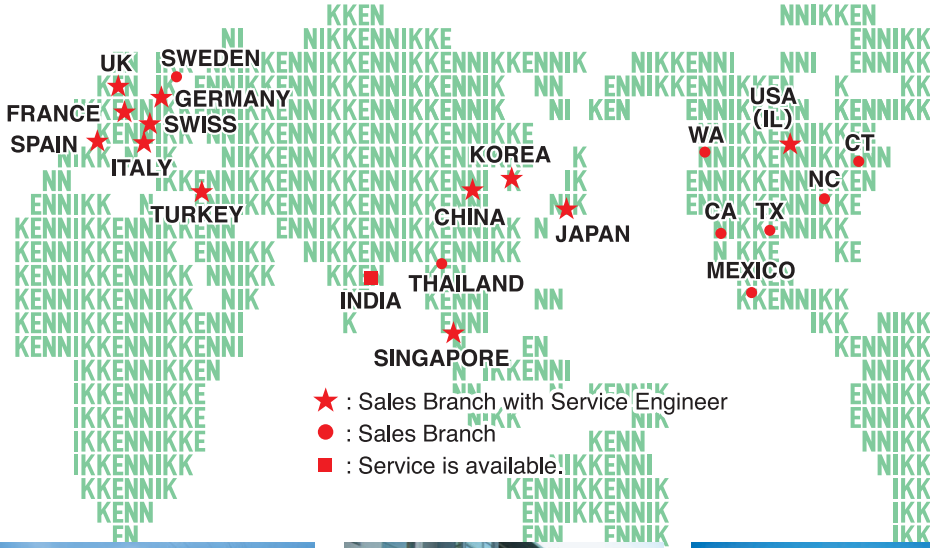

LYNDEX-NIKKEN (U.S.A.)



HERRAMIENTAS LYNDEX-NIKKEN (MEXICO)



NIKKEN EUROPE & NIKKEN U.K (UK)



NIKKEN DEUTSCHLAND (F.R.GERMANY)



PROCOMO-NIKKEN (FRANCE)



KOREA NIKKEN (KOREA)



NIKKEN SCANDINAVIA (SWEDEN)



VEGA INTERNATIONAL (ITALY)



CUTTING TOOL (SPAIN)



NIKKEN CHINA (CHINA)



NIKKEN SWITZERLAND (SWISS)



NIKKEN TURKEY (TURKEY)



SIAM NIKKEN (THAILAND)



NIKKEN ASIA (SINGAPOLE)

★ **U.S.A**
CA, CT, IL, NC, TX, WA

LYNDEX-NIKKEN
1468 Armour Boulevard,
Mundelein, ILLINOIS 60060
Tel.+1-847-367-4800 Fax.+1-847-367-4815

★ **MEXICO**
(From 2014.09)

HERRAMIENTAS LYNDEX-NIKKEN S.A.de C.V.
Av. Hercules #401-13, Fracc. Poligono 3
Santa Rosa Jauregui, Queretaro 76220
Tel.+52-55-8421-8421

★ **FRANCE**

PROCOMO-NIKKEN S.A.S
6, avenue du 1er Mai-Z.A.E.Les Glaises 91127
Palaiseau Cedex
Tel.+33-(0)-1-69.19.17.35 Fax.+33-(0)-1-69.30.64.68

★ **UK**

NIKKEN KOSAKUSHO EUROPE LTD.
Precision House, Barbot Hall Industrial Estate,
Rotherham, South Yorkshire, S61 4RL
Tel.+44-(0)-1709-366306 Fax.+44-(0)-1709-376683

★ **F.R.GERMANY**

NIKKEN DEUTSCHLAND GmbH
Eisenstraße 9c, 65428 Rüsselsheim
Tel.+49-(0)-6142-550600 Fax.+49-(0)-6142-550606

★ **ITALY**

VEGA INTERNATIONAL TOOLS S.P.A
Via Asti N°9 10026-Santena(TORINO)
Tel.+39-011-9497911 Fax.+39-011-9456380

★ **SWITZERLAND**

NIKKEN SWITZERLAND AG
Sumpfstrasse 32-CH-6300-Zug
Tel.+41-(0)-41-748-5000 Fax.+41-(0)-41-748-5001

★ **SCANDINAVIA**
SWEDEN

NIKKEN SCANDINAVIA AB
Bultgatan 13b, 44240 Kungälv
Tel.+46-(0)-303-440-600 Fax.+46-(0)-303-58177

★ **SPAIN & PORTUGAL**

CUTTING TOOL S.L (TOOLING)
PORTUETXE 16, BARRIO IGARRA
E-20018 DONOSTIA-SAN SEBASTIAN
Tel.+34-(0)-902-820090 Fax.+34-(0)-902-820099
NIKKEN EUROPE DIVISORES ESPANA (CNC ROTARY TABLE)
Tel.+34-(0)-669-603433

★ **TURKEY**

NIKKEN KESICI TAKIMLAR SAN. VE ULUSLARARASI TIC. A. S
E5 Uzeri Kucukyali Yanyol Imak Sok.
Kucukyali Sanayi Sitesi A Blok No:5 Maltepe 34852 Istanbul
Tel.+90-(0)-216-518-1010 Fax.+90-(0)-216-366-1414

★ **KOREA**

KOREA NIKKEN LTD.
90B-11L, Namdong Industrial Complex, 170, Namdong-Daero,
Namdong-Gu, Incheon, Korea 405-819
Tel.+82-(0)-32-763-4461 Fax.+82-(0)-32-763-4464

★ **P.R.CHINA**

SHANGHAI ZHONG YAN TRADING CO., LTD.
BUILDING 1/F, #54, No.1089 QINZHOU RD. (N),
SHANGHAI, CHINA
Tel.+86-(0)-216210-2506 Fax.+86-(0)-216210-2083

★ **SINGAPORE**

NIKKEN KOSAKUSHO ASIA PTE, LTD.
268, WOODLANDS CENTRE ROAD, #03-05
WOODLANDS POINT, SINGAPORE 738931
Tel.+65-6362-7980 Fax.+65-6362-7980

THAILAND

SIAM NIKKEN Co., LTD.
127 Moo5 Gauwungsa-Bangturie Road Tambon Tanokkard
Ampher Muangnakhonpathom Nakhonpathom 73000 Thailand
Tel.+66(02)178-0503 Fax.+66(02)178-0504

★ **Branch with service engineer**



Caution for Tooling

- Please use a **NIKKEN** collet for the **NIKKEN** chucks.
- Please use a **NIKKEN** chuck for the **NIKKEN** collets. may not be performed 100% using on the other makers chucks.
- Please be careful not to inflict personal injury at your handling of cutting tools.
- Please clean the contact surface on a holder & cutting tool shank.
- Please pay attention to prevent from the rust at the storage. We will recommend to use **NIKKEN TOOLINGS with RPT process for rust prevention. Due to the optical system to detect the tool existing on the tool magazine of certain machines, NIKKEN's RP treated tooling may not be detected. Please check your machine's specifications very carefully to avoid this problem before you purchase our RP treated tooling. The taper connection of the tool shank with RPT treatment is more stuck than the taper connection of the tool shank without RPT treatment. Then, the unclamping force for the tool with RPT treatment is required 20% stronger than the unclamping force for the tool without RPT treatment. Please be**

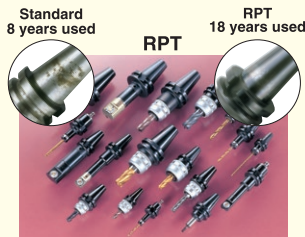

careful to check the unclamping force of your M/C, when the tool with RPT treatment is chosen.

MTA

- Please insert the tool shank into the bore of the holder with adjusting the tang location, and hold them with facing tool front end upwards, and hit the bottom end of the holder (pull stud end) by copper hammer hardly.
- For removal of the tool, insert a bar into tang hole and hit the bar by hammer with special care to prevent the tool from popping out.
- Please clamp side lock screw in case of coolant through application. **For high pressure coolant through application, please use milling chuck, slim chuck or side lock holder instead of MT adapter.**

MTB

- Please insert the tool shank into the bore of the holder and tighten the draw bolt for the setting.
- For removal of the tool, loosen the bolt at couple rotation and hit the bolt head by a hammer in order to remove the taper fitness, then remove the bolt.

SCA, SCC

- When setting of side cutter or metal saw onto the arbor, please adjust the location of the drive key.

JTA

- When setting drill chuck onto the arbor please put the chuck onto the arbor with adjusting the locations of male & female tapers and hit the bottom end of the holder (pull stud end) by copper hammer.
- Please use **NIKKEN SLIM CHUCK** for high precision and high speed operation.

NPU

- Please insert the drill shank into the bottom, and chuck the shank with the total chucking length of **NPU**.
- Please check the run-out accuracy before machining especially for the small diameter drill.
- When setting the drill onto the chuck, set the drill into the chuck and tighten the chuck ring by hand then tighten the ring by attached spanner to complete.

FMA, FMB, FMC, SMA, SMB, SMS

- Please use the bolt specified by the cutter maker.
- When setting the face milling cutter onto the arbor, insert the spigot of the arbor into the cutter bore and minimize the backlash between the drive key and the slot against the direction of rotation, then tighten the end bolt.
- For the cutter with coolant through the body, please check the coolant pass in the arbor and the cutter before machining.
- For high speed application, please perform the balancing operation with the cutter and insert tips fitted.

PS

- The pull stud is considered to consumption item and should be replaced periodically. The guide line of replacement is ;
Without hole : 3 years or 150,000 times of ATC.
With coolant hole : 2 years or 100,000 times of ATC.

- The specification are subject to be changed without notice.
- The photo. of the machine is permitted to use from **BROTHER**. The content in this catalogue is published responsible by **NIKKEN**.
- Please contact us for the "Overseas Warrantee Contract".

NIKKEN KOSAKUSHO WORKS, LTD. OSAKA, JAPAN.

5-1, 1-chome, Minamishinden, Daito-shi, Osaka-fu, Japan. Telephone:072-869-5820 Telefax:072-869-6220

U.S.A
CA, CT, IL, NC, TX, WA

LYNDEX-NIKKEN
1468 Armour Boulevard,
Mundelein, ILLINOIS 60060
Tel.+1-847-367-4800 Fax.+1-847-367-4815

KOREA

KOREA NIKKEN LTD.
90B-11L, Namdong Industrial Complex, 170, Namdong-Daero,
Namdong-Gu, Incheon, Korea 405-819
Tel.+82-(0)-32-763-4461 Fax.+82-(0)-32-763-4464

MEXICO
(From 2014.09)

HERRAMIENTAS LYNDEX-NIKKEN S.A.de C.V.
Av. Hercules #401-13, Fracc. Poligono 3
Santa Rosa Jauregui, Queretaro 76220
Tel.+52-55-8421-8421

P.R.CHINA

SHANGHAI ZHONG YAN TRADING CO., LTD.
BUILDING 1/F, #54, No.1089 QINZHOU RD. (N),
SHANGHAI, CHINA
Tel.+86-(0)-216210-2506 Fax.+86-(0)-216210-2083

FRANCE

PROCOMO-NIKKEN S.A.S
6, avenue du 1er Mai-Z.A.E.Les Glaises 91127
Palaiseau Cedex
Tel.+33-(0)-1-69.19.17.35 Fax.+33-(0)-1-69.30.64.68

SINGAPORE

NIKKEN KOSAKUSHO ASIA PTE, LTD.
268, WOODLANDS CENTRE ROAD, #03-05
WOODLANDS POINT, SINGAPORE 738931
Tel.+65-6362-7980 Fax.+65-6362-7980

UK

NIKKEN KOSAKUSHO EUROPE LTD.
Precision House, Barbot Hall Industrial Estate,
Rotherham, South Yorkshire, S61 4RL
Tel.+44-(0)-1709-366306 Fax.+44-(0)-1709-376683

THAILAND

SIAM NIKKEN Co., LTD.
127 Moo5 Gauwungsai-Bangturie Road Tambon Tanokkard
Ampher Muangnakhonpathom Nakhonpathom 73000 Thailand
Tel.+66(02)178-0503 Fax.+66(02)178-0504

F.R.GERMANY

NIKKEN DEUTSCHLAND GmbH
Eisenstraße 9c, 65428 Rüsselsheim
Tel.+49-(0)-6142-550600 Fax.+49-(0)-6142-550606

ITALY

VEGA INTERNATIONAL TOOLS S.P.A
Via Asti N-9 10026-Santena(TORINO)
Tel.+39-011-9497911 Fax.+39-011-9456380

<http://www.nikken-kosakusho.co.jp>
e-mail : export@nikken-kosakusho.co.jp

SWITZERLAND

NIKKEN SWITZERLAND AG
Sumpfstrasse 32-CH-6300-Zug
Tel.+41-(0)-41-748-5000 Fax.+41-(0)-41-748-5001

SCANDINAVIA
SWEDEN

NIKKEN SCANDINAVIA AB
Bultgatan 13b, 44240 Kungälv
Tel.+46-(0)-303-440-600 Fax.+46-(0)-303-58177

SPAIN & PORTUGAL

CUTTING TOOL S.L (TOOLING)
PORTUETXE 16, BARRIO IGARRA
E-20018 DONOSTIA-SAN SEBASTIAN
Tel.+34-(0)-902-820090 Fax.+34-(0)-902-820099
NIKKEN EUROPE DIVISORES ESPANA (CNC ROTARY TABLE)
Tel.+34-(0)-669-603433

TURKEY

NIKKEN KESICI TAKIMLAR SAN. VE ULUSLARARASI TIC. A. S
E5 Uzeri Kucukyali Yanyol Irmak Sok.
Kucukyali Sanayi Sitesi A Blok No:5 Maltepe 34852 Istanbul
Tel.+90-(0)-216-518-1010 Fax.+90-(0)-216-366-1414

■Please give your order to the following agent.

D.IG.5

●Specifications are subject to change without notice.