

Machine Enhancements & Spindle Optimisation



On Machine Enhancements

Work Holding

Our range of modular work holding integrates seamlessly with our multi axis platform approach. Zero point location and modular base rail technology are available to suit NIKKEN standard table interfaces. This allows rapid change over of component fixtures and work holding set ups.

Standard clamping modules, centring vices and chucks are all interchangeable with machine bed and additional axes, in addition a wide range of standard and bespoke trunnion set ups are available as options.

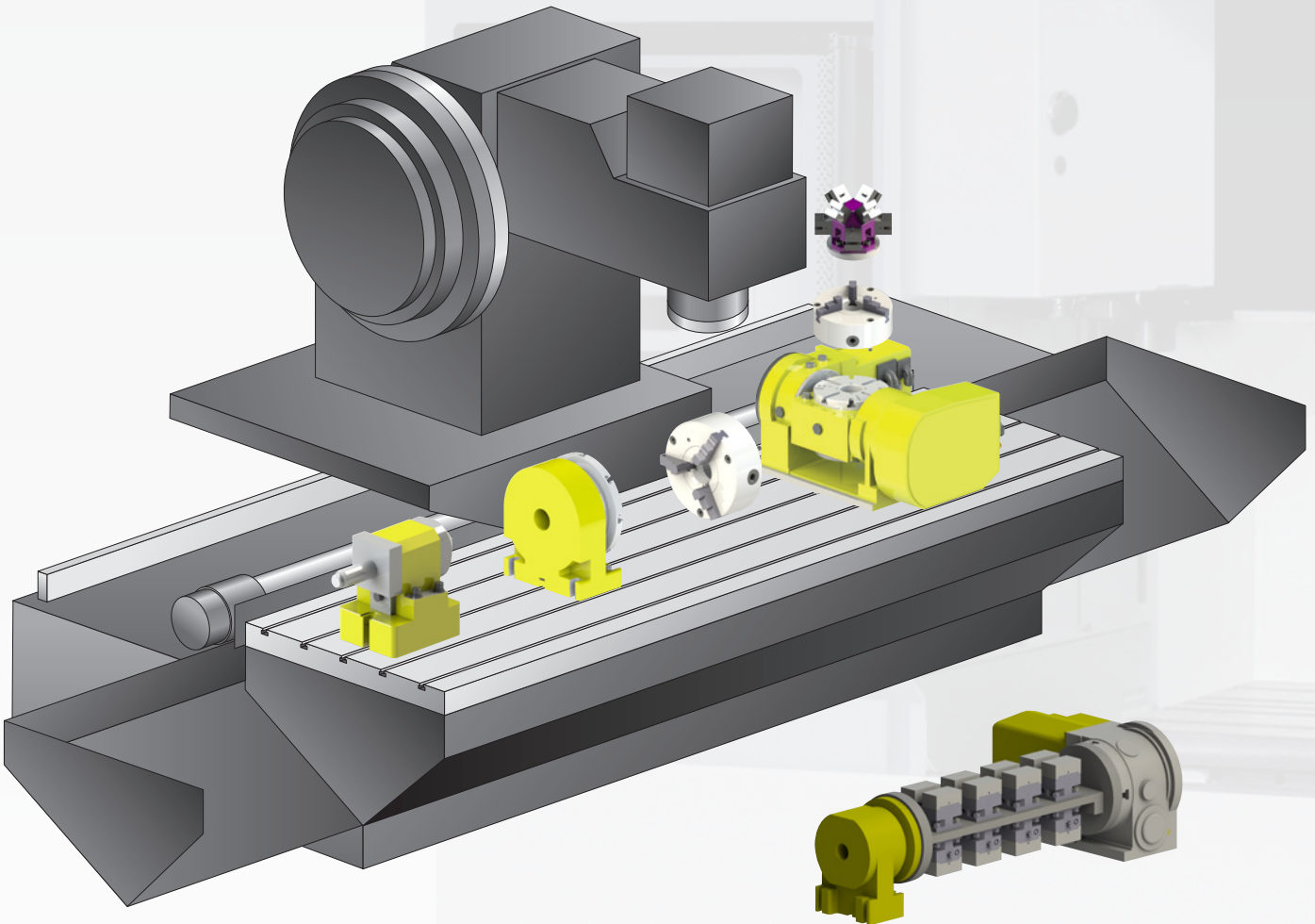

elbo controllli  **NIKKEN** Productivity Options

Featuring a complete range of Tool Presetting, Tool Inspection and Tool management Systems

Spindle optimisation

Contents

Rotary Tables

NIKKEN provide a wide range of on Machine enhancements to create a flexible multi-axis machine platform essential for today's highly competitive market.

Our range of 4th and 5th axis tables open up the possibilities of part manufacture in a single cycle, improving process flow and productivity!

NIKKEN's extensive product range combined with technical expertise, training and after sales service come together with the Okuma range of machine tools to offer a superior end-to-end experience that allows our customers the opportunity to successfully compete in the global market.

Advanced Tooling System Interface

NIKKEN provide a complete range of advanced spindle tooling to take advantage of dual 'taper & face contact' spindle interfaces.

All machining disciplines benefit from the additional rigidity, improved accuracy and repeatability the 2-lock system provides. This allows cutting strategy and parameters to be optimised.

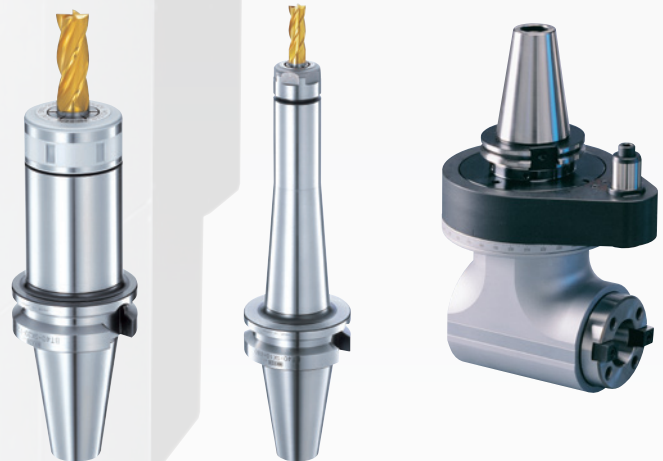
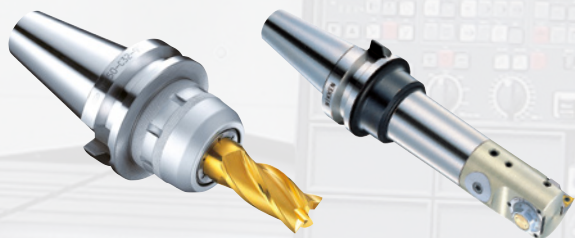

Spindle Attachments

A range of universal and fixed angle heads are available to enhance capabilities to additional details and features that would normally require secondary operations and resources.

The range is complemented by the NIKKEN-ALBERTI Turboflex system which can deliver spindle output speeds of up to 60,000rpm offering optimum solutions for small diameter cutters.



Section	Page
Machine Enhancements, NIKKEN Rotary Tables	4 - 5
4 Axis Solutions	6 - 7
5 Axis Solution	8 - 9
Spindle Optimisation NC Tooling System	10 - 11
Spindle Optimisation Angle Heads and Turboflex	12 - 13
Productivity Options Tool Presetters	14 - 15

On Machine Enhancements

Rotary Tables

NIKKEN Kosakusho Works Limited, located in Japan, annually produces over 3,500 rotary tables, employs a global workforce in excess of 550 and has earned a reputation for producing quality products and demonstrating total commitment to its clients.

Our unique table construction delivers unrivalled performance and reliability, which are fully supported by our team of factory trained Service Engineers and Advanced Manufacturing Specialists.

NIKKEN Tables are the perfect fit for the Okuma range which offer the opportunity to combine operations and multi part load to dramatically improve productivity.

Machine Compatibility

Machine Model	4th Axis Rotary Table	5th Axis Rotary Table
MB-46VAE		
MB-46VBE	CNC202OSP4	5AX-130OSP4
GENOS M 460-VE		
MB-56VAE		
MB-56VBE C	NC260OSP4	5AX-201OSP4
GENOS M 560-V		
MILLAC-44V II	CNC202OSP4(FA)	5AX-130OSP4(FA)
MILLAC-468V II	CNC260OSP4(FA)	5AX-201OSP4(FA)
MILLAC-561V II	CNC260OSP4(FA)	5AX-350OSP4(FA)
MILLAC-611V II	CNC401OSP4(FA)	5AX-350OSP4(FA)
MILLAC-761V II	CNC401OSP4(FA)	5AX-350OSP4(FA)
M-852V II	CNC501OSP4(FA)	5AX-350OSP4(FA)
M-1052V II	CNC601OSP4(FA)	5AX-350OSP4(FA)

Rotary Tables

Industry 4.0

Unique Table Construction

Casting

NIKKEN Rotary Tables utilise fine grain, high-density, Grey Cast Iron castings, which are stabilised prior to finishing operations offering long term stability, low distortion, high strength and rigidity.

NIKKEN are leading the way by utilising the latest, cloud-based technology to access big data during the lifetime of our products. Providing you with full **Industry 4.0** compliance.

Being able to sense and predict failure is a major aspiration for optimising machine uptime, with this goal in mind NIKKEN have created our new **NIKKEN I/O**.

A compact continuous condition monitoring system designed for our NC Tables.

By fitting an array of sensors inside our rotary tables that send real-time data wirelessly while in production, the **NIKKEN I/O** offers a comprehensive range of monitoring including: Backlash measurement, collision detection, oil condition monitoring and power consumption.



Gearing

For gear driven tables NIKKEN uses a Patented Solid Carbide Worm Screw held in a four point bearing eccentric housing. This is matched with a Heat Treated (HV1 100) Steel Worm Wheel. Delivering minimal wear compared to traditional Steel/Bronze configurations ensuring accuracy and durability.

Bearings & Seals

Independent Tubular Thrust and Radial Bearings deliver high rigidity, concentricity and provide enhanced levels of vibration dampening. Inner bearing race is produced from hardened steel (HRC58-60) and the faceplate/ bearings are sealed via a special Teflon ring to prevent ingress of moisture.



For details on NIKKEN Rotary Tables contact: enquiries@nikken-world.com

On Machine Enhancements

Rotary Tables

NIKKEN NC Tables offer unrivalled quality and performance by optimising production and can be configured for all types of Machining centres.

NIKKEN offer a wide range of 4th and 5th Axis Tables that can be easily configured to a variety of work holding solutions such as Trunnion fixtures, built in rotary joints for facilitating hydraulic clamping, chucking and vice systems. The range consists of gear driven and direct drive units which can be controlled by the machine tool directly or via our own Alpha21 control system.



Rotary Tables

Servo

Standard Rotary Tables

NIKKEN offer a comprehensive range of tables for Vertical machines. Face plate diameters range from 105mm to 1600mm and Motor positions can be left hand, right hand or back mounted to ensure units are able to be mounted in the most efficient position.

Options Include:

- Built in Rotary Joints
- Direct encoders
- Zero Point Quick change solutions
- Machine Vices
- Trunnion systems
- Modular Work Holding and clamping
- Manual and Power Chuck systems
- Manual, Pneumatic and Hydraulic
- Tailstocks
- TAT end Support Units



Specification

NIKKEN Tables are suitable for all Okuma control specifications:

- FANUC
- HEIDENHAIN
- SIEMENS

They can also be configured with the NIKKEN A21 control system

Control Via:

- M-Code
- Macro 'B' function for FANUC (Direct Angle Command)



Big Bore Tables

Our latest generation of Ultra Big Bore tables feature the same renowned internal construction, including the usual mono-block spindle design, which provides large through bore access for large shaft components.

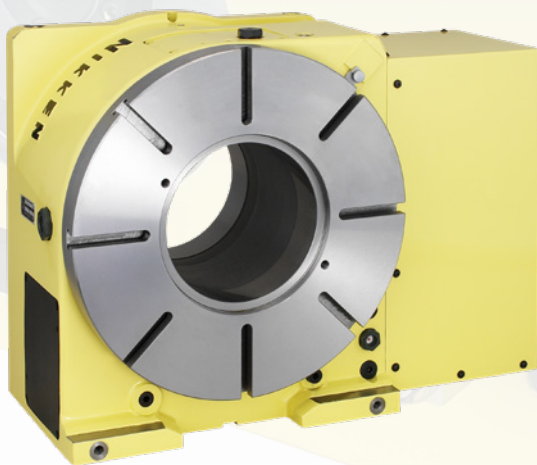

Direct Drive Tables

To complement our range of geared tables we also feature a range of Direct Drive Tables, these offer high Rotational speed and high rates of acceleration/ deceleration- our DD-250F-150 model delivers an impressive 150rpm



For details on NIKKEN Rotary Tables contact:
enquiries@nikken-world.com

On Machine Enhancements

5 Axis Solutions

NIKKEN are at the forefront in the field of 5 axis tables, we feature a comprehensive range to suit Okuma machining centres. Okuma offers the opportunity to maximise productivity by combining multiple operations, and are ideally suited for complex multi-faceted parts or components with compound detail to be machined.

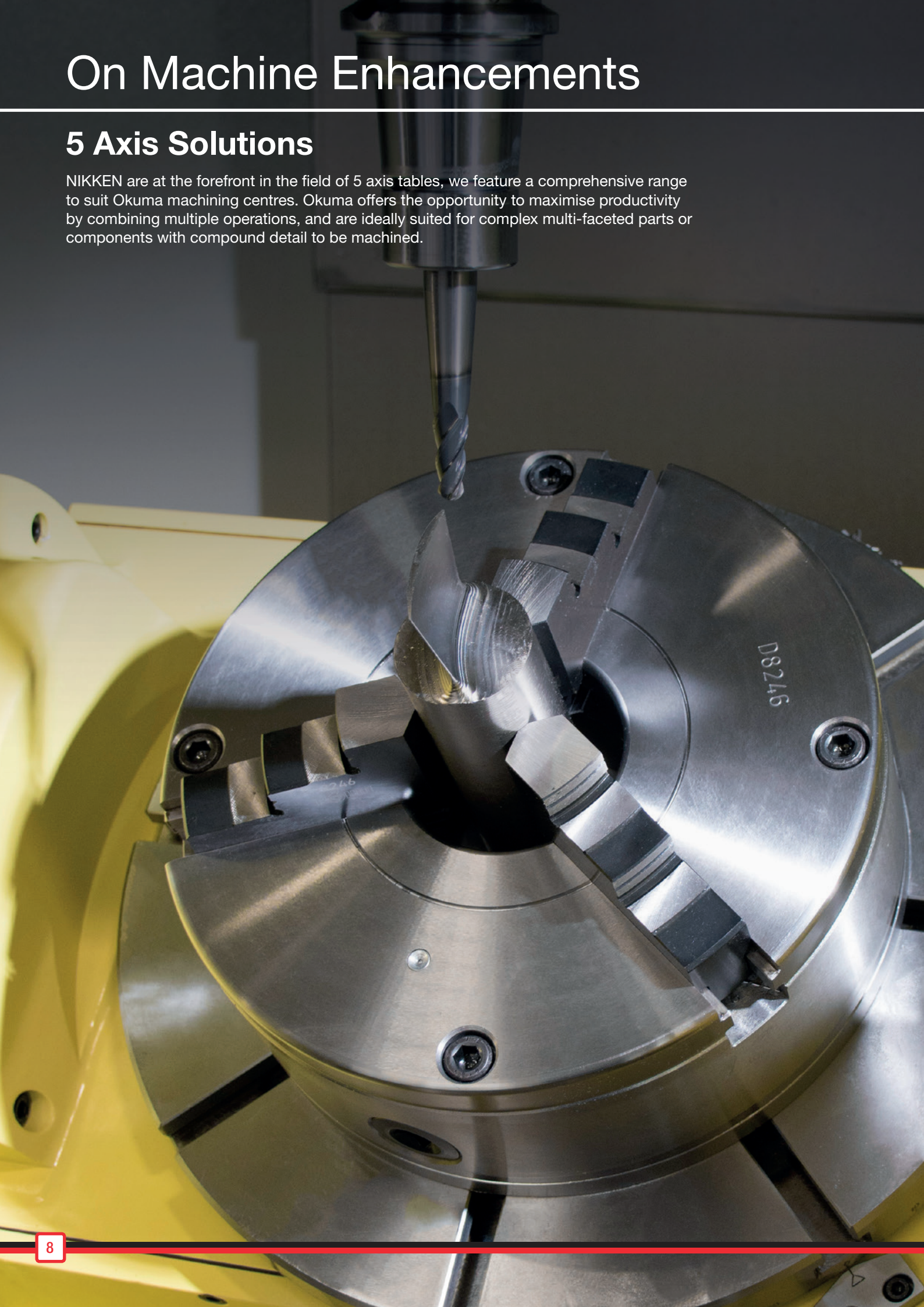

5 Axis Solutions

Accessories

5 Axis Tables

5 Axis Solutions are an ideal addition to any Okuma machining centre. They are perfectly suited to hold complex parts, by reducing set ups they optimise quality and productivity. In many instances a part can be manufactured and inspected in a single operation.

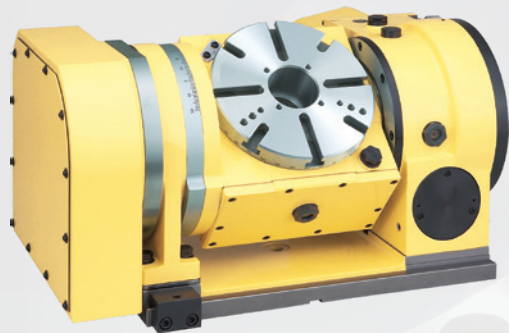

Compact 5 Axis units can be mounted along the Y Axis of a vertical Machine to facilitate part manufacture in a single set up.

A comprehensive range of modular vices and chucking systems are available to compliment NIKKEN 5 Axis solutions.

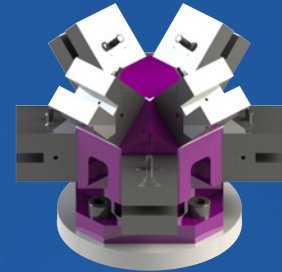

"Sputnik" multi part clamping system

Tables can be mounted along the X axis of the machine to offer Trunnion type 5 Axis solutions, these units have face plates on the centre of tilt axis rotation to maximise working envelope.

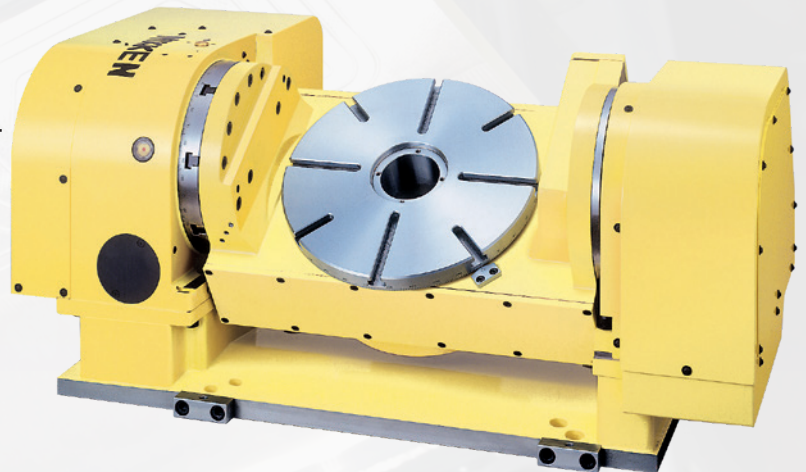

Top Mounted Tables for Horizontal Machining Centres

Another 5 axis solution is to combine a NIKKEN top mounted Rotary Table with the 'B' axis pallet of a horizontal machine. This can be pallet changed by utilising our swing box system. This combination offers 5 Axis capability with all the benefits of a production horizontal machine.

- High Rigidity
- Enhanced Swarf Management
- Larger capacity Tool Carousel

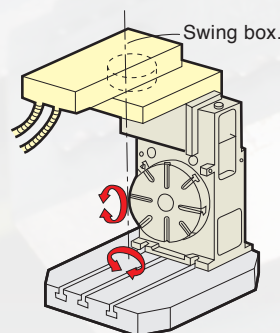

For details on NIKKEN 5 Axis solutions contact: enquiries@nikken-world.com

Spindle Optimisation

Advanced Tooling System

For many years NIKKEN have been at the forefront in the field of precision spindle tooling, we offer a full range of systems to meet all the essential requirements when Milling, Drilling, Reaming, Boring and Threading.

Our standard tapers offer a better than AT3 interface to the machine spindle. This optimises performance whilst helping to protect the machine spindle from the effects of vibration and cutting forces. This can be further enhanced with the NBT connection that offers simultaneous taper and face contact with the spindle for 30, 40 and 50 tapers.



NC Tooling System

Pro End Mill - A unique tool from NIKKEN and the ultimate solution for Indexable Milling up to 32mm, Taper and Face contact as Standard for maximum rigidity, Unique "MD" anti-vibration technology.

Multi-Lock Milling Chuck - The market leading solution for cylindrical tools shanks up to 42mm. Available in a wide range of lengths and diameters. Our unique design and manufacturing processes ensure long lasting performance.

Mini-Mini Advanced Alpha - Our ultimate solution for small diameter end mills (up to 12mm). Tools are gripped up to the front nose of the chuck, minimising overhang and maximising rigidity. The essential requirement for milling with small diameter cutters, our unique TiN bearing design allows high clamping forces without distortion to maximise rigidity and accuracy, balanced to G2.5 for high speed applications.

Slim Chuck - The precision standard for collet chucks. The latest slim chuck from NIKKEN incorporates the Tin Bearing Nut that when combined with the 8 degree SK collet, delivers unrivalled performance in terms of accuracy, repeatability and rigidity. A wide range of gauge length and nose profiles offers total flexibility to solve any precision application.

Zero Fit - Our solution for improved accuracy. Run out is adjusted while in the machine spindle and readings of 0-2u are easily achieved. We strongly recommend this solution for precision operations such as reaming where tool run out is of critical importance.

RAC Modular Boring (25mm-580mm) - The new RAC boring system from NIKKEN offers twin cutting edges and rough boring is achieved efficiently by our new generation design. Utilising ultra-precision ground serrations in the cartridges to counter cutting forces and deliver a smooth cutting action.

ZMAC Modular Boring (16mm-180mm) - Our latest ZMAC advanced sets new standards in the field of precision boring. The new cartridge design allows for easy micron adjustment while the ZMAC boring head design ensures that the cutting edge is always supported by the boring head body to ensure maximum rigidity. This combination makes it easy to reliably achieve high dimensional precision and superior surface finishes.

EMAC-Digital Boring - Our new EMAC system utilises a digital head with a series of accessories and boring bars to deliver precision boring capacity of 6-110mm in just one standard boring kit. Assemblies are easily constructed to achieve the desired bore diameter and perfect adjustment is made via the digital interface.

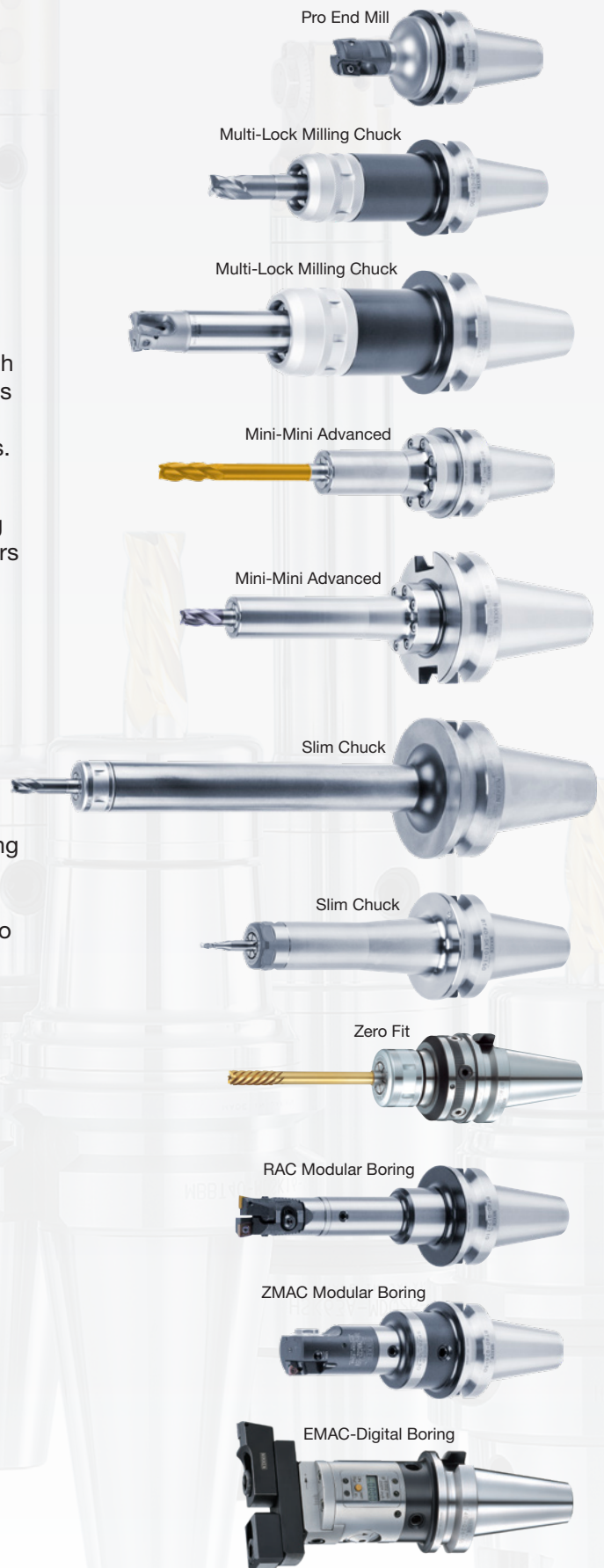

For details on NIKKEN advanced tooling systems contact:
enquiries@nikken-world.com

Spindle Optimisation

Angle Heads

With 35 years of experience and over 50,000 products installed, NIKKEN-ALBERTI are delighted to be able to offer a wide range of Angle Heads and attachments to enhance the functionality of any Vertical Machining Centre. Whether that be increasing the output RPM of the spindle or machining internal features otherwise impossible to achieve by other means, NIKKEN have a solution.

All our attachment bodies are manufactured from GS600 stabilised spheroidal Cast Iron to better absorb vibration and deliver higher levels of thermal stability, further enhanced by a matt Chrome finish. Produced using 'lost wax' process moulding technology, this delivers the highest levels of purity and stability allowing NIKKEN-ALBERTI to produce lighter compact head designs with the necessary rigidity to meet the demands of the toughest applications.

All units come in a sturdy case and are complete with wrenches, Instruction manual, test Certificate and stopper block (Machine Specific).



Angle Heads

Standard & Universal Angle Heads

NIKKEN provide a wide range of standard and Universal Angle heads. Designed for integration to the machine tools ATC and to enhance the capability of any standard 3 Axis machine platform.

A comprehensive range of heads are available for selection and integrate via a standard twin location spindle stopper block. Heads are now available with NIKKEN SK output.

Optional specifications such as through coolant capability and twin outputs are available – please refer to NIKKEN-ALBERTI standard Angle Head Brochure.

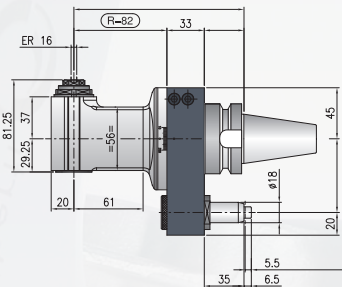
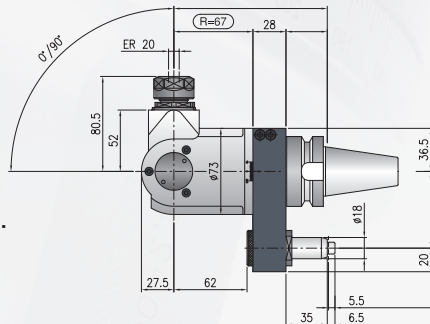

Integration



Single or twin location stopper blocks are available for the latest Okuma Range of Machines, these locations are suitable for mechanical and Turboflex (air driven) heads.



Airline kit for Turboflex system

Turboflex & Slimline 90° Heads

The Turboflex & Slimline range provide the opportunity to increase spindle speed outputs.

Turboflex heads are driven by air, which is delivered through the pin/air location on the stopper block. The machine spindle is static and the output speed is fixed by the air motor. Turboflex options offer long duty cycles- up to 500 hours constant running.

Slimline heads are spindle driven and output is controlled via the machine spindle speed (subject to output ratio).

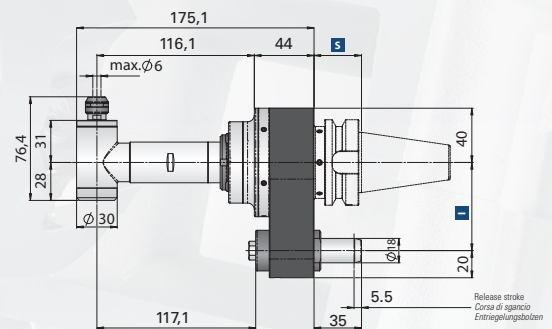

Turboflex Speed Increaser 20/30/60.000 RPM

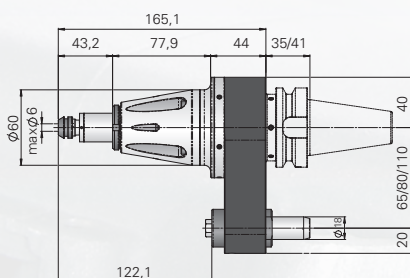

NIKKEN Turboflex heads utilise an air motor inside the main tool body to drive the tool (machine spindle remains static). These heads offer high output speeds and long duty cycles, ideally suited to small diameter tools where applications demand high spindle speeds.



For details on NIKKEN spindle optimisation contact: enquiries@nikken-world.com

Productivity Options

Tool Presetting

ELBO CONTROLLI - NIKKEN offer a wide range of Centralised Tool Setting Solutions. A single tool presetter can be utilised for multiple machines and spindle types.

- Tool Inspection - run out and geometry check to minimise non-conformance/scrap caused by tool errors
- Non-contact measurement of tools prevents damage to cutting tool and machine spindle
- Next Job pre-planning and tool setting done while machines are still producing, significantly reducing down time.



E346i

E460N



NIKKEN KOSAKUSHO WORKS LIMITED and ELBO CONTROLLI SRL, a major player in the fields of Tool Presetting, Inspection and Tool Management Systems, have now commenced a new global Strategic Alliance.



Entry level Presetter

E346i Tool presetter complete with ISO spindle and re-setting gauge

Features:

- Granite column and base
- Digital camera
- Interchangeable spindle

Measure Range 340mm Diameter
 460mm Length

- | | |
|-----------------------------|---|
| Interchangeable Spindle | ✓ |
| Cutting Edge Inspection | ✓ |
| Tool Inspection | ✗ |
| Label Printer Compatible | ✓ |
| Offset Transfer via Network | ✗ |
| Tool Management | ✗ |

Network ready Presetter

E460N Tool presetter complete with ISO spindle and re-setting gauge

Features:

- Granite column and base
- Digital camera
- Interchangeable spindle with vacuum clamping
- Tool Management with universal Post Processor generator

Measure Range 400mm Diameter
 600mm Length

- | | |
|-----------------------------|---|
| Interchangeable Spindle | ✓ |
| Cutting Edge Inspection | ✓ |
| Tool Inspection | ✓ |
| Label Printer Compatible | ✓ |
| Offset Transfer via Network | ✓ |
| Tool Management | ✓ |



For details of how NIKKEN can improve your productivity contact: enquiries@nikken-world.com



The Spirit of Innovation

NIKKEN Innovation Centre Europe (NICe)
Advanced Manufacturing Park, Brunel Way
Rotherham, South Yorkshire S60 5FS

Telephone: +44 1709 366306

www.nikken-world.com



Scan here for information about (NICe)
our European Innovation Centre

We reserve the right to modify specifications at any time



CAT-EU-OEM-OKU-01